

# Quick Exhaust Valve

## Hydraulic

1/2" FEMALE NPT, 6,000 PSI

Model 13QS38 / 13QS39 (H2S)



Conforms to the SEP category of the European Pressure Equipment Directive  
Issue No. 97/23/EC

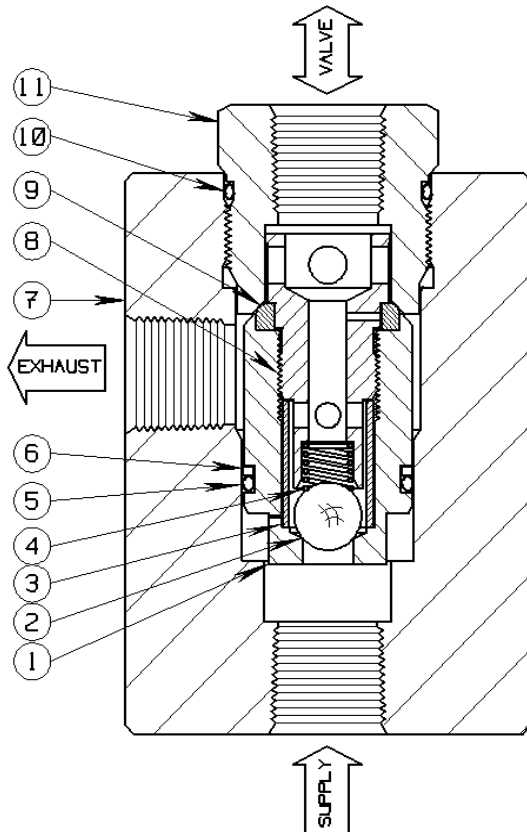

The **13QS38** is a two position, poppet operated control valve assembly. This hydraulic Quick Exhaust valve has a maximum working pressure of **6,000 PSI (413 bar)** with **high flow exhaust** capacity. It establishes flow from supply to valve (inlet to outlet) connections to open a Surface Safety Valve (SSV) or Surface Controlled Subsurface Safety Valve (SCSSV) actuator automatically with each application of operating pressure.

A loss or significant decrease of inlet supply pressure will unseat the Poppet to quickly establish high volume reverse flow exhaust. Rapid closure of a hydraulic actuator is assured with the use of a Sigma Quick Exhaust Valve.

The 13SQ38 utilizes a small internal orifice that bypasses the Poppet assembly to provide thermal expansion capability. It also minimizes the effects of pump cycling or small volume fluid leaks, to maintain proper operating volume or pressure.

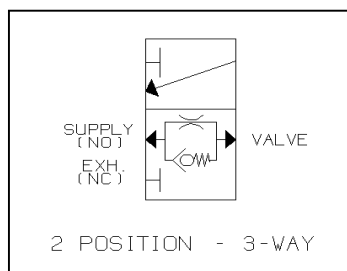

### PARTS LIST:

- |                       |                 |
|-----------------------|-----------------|
| 1. Valve Poppet       | 7. Valve Body   |
| 2. Ball *             | 8. Seal Guide   |
| 3. Restriction Sleeve | 9. Kel-F Seat * |
| 4. Spring *           | 10. O Ring *    |
| 5. O Ring *           | 11. Retainer    |
| 6. Back Up Ring *     |                 |

\* Indicates parts included in a Repair Kit

**SIGMA**  
VALVES

# Sigma Model Number 13QS38

1/2" FEMALE NPT, 6,000 PSI

---

## Product Specifications

---

**Flow Control Application:** Normally Open

**Control Function:** Three-Way – Poppet Assembly Operated

**Flow Capacity:** High Flow Service

**Pressure Rating Body (Control Ports):** 6,000 PSI maximum (413 bar)

**Seal Material:** Viton and Kel-F

**Connection Size (Body):** 1/2-14 Female N.P.T. (Supply, Valve, Exhaust)

**Wetted Component Material (Metal):** 316 Stainless Steel and 17-4PH SS

**Mounting:** Field Mount (Standard)

**Orifice:** .718 Diameter      **Cv Factor:** 4.33

**Weight:** 5 Lbs.

**Operating Temperature:** -20° F to +250° F (-29° C to +121° C)

**Overall Dimensions:** 4-5/8 Height x 2 3/8 Diameter (11.75 cm Height x 7.3 cm Diameter)

**Pressure Equipment Directive (PED):** This product conforms to the SEP Category of the European P.E.D.

### **Installation and Maintenance Instructions:**

Install between the interface valve and the actuator. This is done by threading the pipe or fitting from the control system into the port labeled "Supply". The piping from the actuator is threaded into the port labeled "Valve". A significant loss in pressure within the control system will trigger an exhaust of the actuator through the valve port and out the exhaust port. Sigma recommends the use of appropriate thread sealant for each port connection.

### **Shelf Position Port Status**

<b>Supply Inlet</b>	Instrument supply pressure open to cylinder (Actuator)
<b>Valve</b>	Outlet Pressure to cylinder (Closed to Exhaust Port)
<b>Exhaust</b>	Depressurizes cylinder upon loss of Supply Inlet

### **Repair Kit Information**

Repair Kits contain all of the Seals and other components typically replaced when repairing the assembly. In order to maintain optimum operating control function, Sigma recommends changing the Repair Kit items once every two (2) years.