

DELTA ENGINEERING srl

Via Sabbio, 93 – 24044 Dalmine (BG) – ITALY – ph. +39.035.561140 – fax. +39.035.563541 – info@deltaeng.it – www.deltaeng.it



CLIENT
INFORMATIONS

Cliente:
Client:

Ordine Cliente:
Client P.O.

Progetto / Project:
Impianto / Plant:
Commessa / Job n°:

DANIELI S.P.A.

16244016 OE

DP0VFN-RF01-G0000-DS007 REV.00

JOB
INFORMATIONS

Oggetto. :
Object:

Vs. Commessa. :
Your Job N°:

AIR BLADES SYSTEM

DP0VFN021281

Materiale. :
Material:

DOCUMENT
INFORMATIONS

Nome del Documento:
Document title:

Documento n°
Document n°

VENDOR DATA BOOK

VDB-001

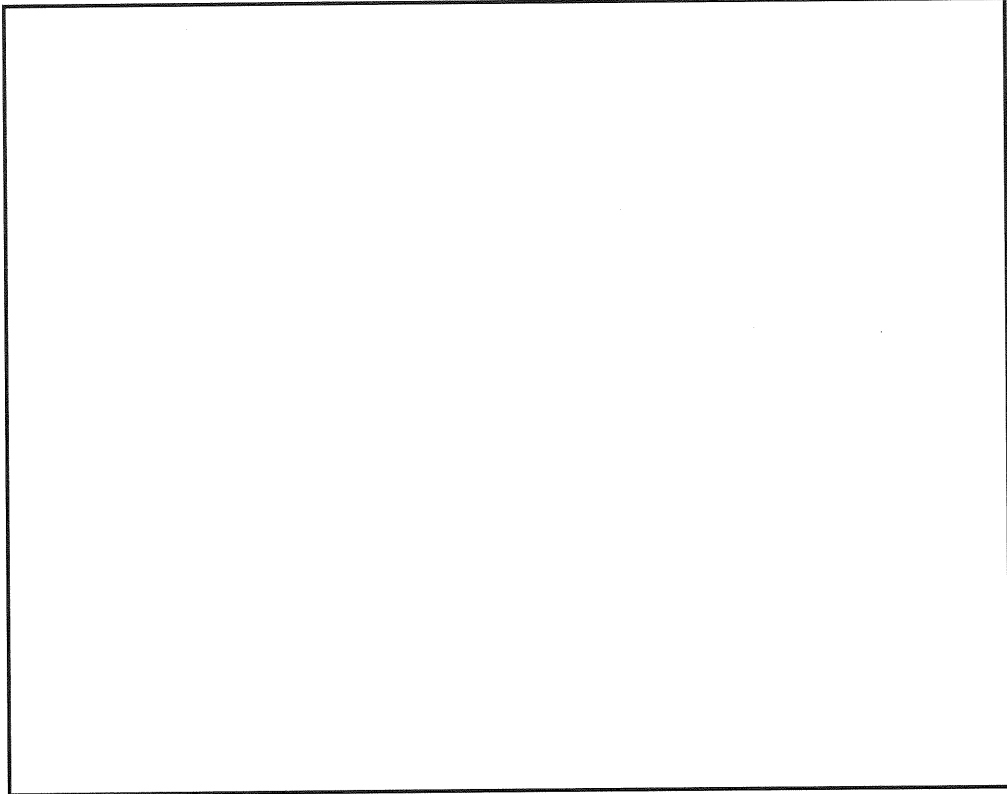

0	FIRST ISSUE	26/01/15	A.D.	P.R. – E.A.	P.E.B.
Rev.:	Descrizione:	Data:	Preparato da:	Controllato da:	Approvato da:
Rev.:	Description:	Date:	Prepared by:	Checked by:	Approved by:



Documento:
Document:
Oggetto:
Object:

VENDOR DATA BOOK

AIR BLADES SYSTEM FOR DRYER

1

OPERATIONAL & MAINTENANCE MANUAL

1.1 Blower Installation and Operation Manual



Operation and Maintenance Manual

Sonic 300 / 300C

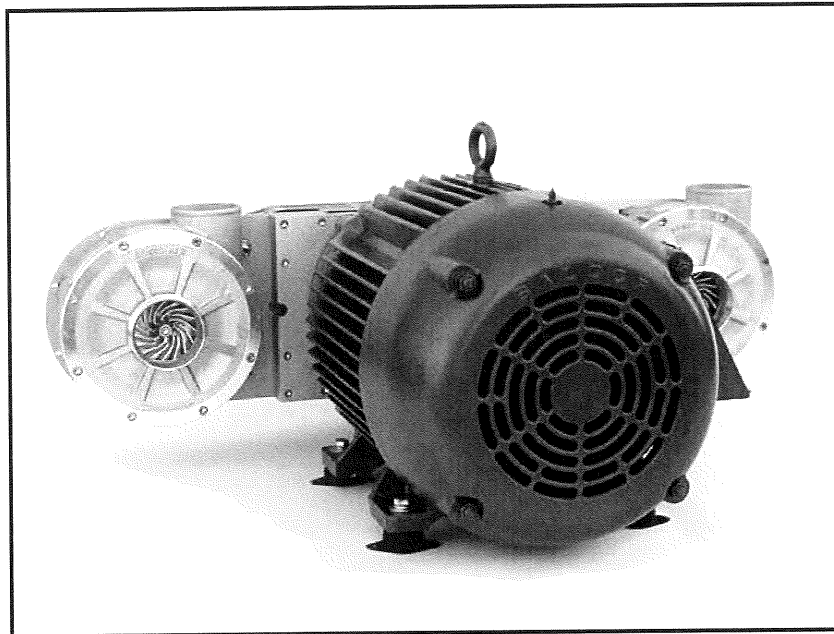

Sonic Air Systems
1050 Beacon Street
Brea, California 92821
Tel: 714-255-0124 Fax: 714-255-8366
www.sonicairsystems.com





Operation and Maintenance Manual

Sonic 300 / 300C

O&M-300

Release Date: February 18, 2002

Prepared by: _____
Jeff Johnson

Approved by: _____
Mike Pankey

Approved by: _____
Terry Riley

Approved by: _____
Dan VanderPyl

*This document has an electronic master, which resides in the Document Control System (DCS).
The authorizing signatures are on a hard copy of this document held by Document Control.*

Revision Log

Rev. Ltr.	Rel. Date	Chg Req.	Description
New	02/18/02	N/A	Initial Release
A	10/08/02	N/A	Revised Belt Gap Arrows
B	02/25/03	-	Revised Address
C	05/12/03	-	Revised CE Label
D	12/15/03	-	Upgraded Drive System



Table of Contents

1 Sonic 300 / Sonic 300C..... 1

1.1 Introduction 1

1.2 Blower Performance..... 1

1.3 Product Profile..... 2

1.4 Typical Applications 3

2 Initial Inspection 4

3 Safety Instructions 5

3.1 Electrical..... 5

3.2 Mechanical 5

4 Installation and Adjustments..... 6

4.1 Lifting and Handling 6

4.2 Blower Location 6

4.3 Belt Installation 8

4.4 Blower Head Mounting Adjustment..... 9

5 Electrical Wiring, and Start-Up 13

5.1 Motor Wiring..... 13

6 Blower Specifications 14

6.1 Blower Specification Sheet 14

6.2 Assembly Drawing 15

6.3 Parts List..... 16

6.4 Motor / Bushing Cross Reference 18

7 Periodic Maintenance 19

7.1 Maintenance Schedule..... 19

7.2 Torque Specifications..... 19

7.3 Belt Replacement Procedure 19

7.4 Belt Tensioner Service 21

7.5 Recommended Spares 23

8 Troubleshooting 24

9 Performance Guarantee 25

10 Warranty Policy 26

11 24/7/365 Service Program..... 27

12 Sonic Repair Policy 28



Table of Figures

Figure 1 - Sonic 300C (Front View).....	1
Figure 2 - Sonic 300C (Back View)	1
Figure 3 - Sonic Nameplate.....	4
Figure 4 – Blower Serial Number.....	4
Figure 5 - Lifting Point.....	6
Figure 6 - Remove Belt Guard	9
Figure 7 - Install Belt.....	9
Figure 8 – Adjust Belt Gap.....	9
Figure 9 – Install Belt	9
Figure 10 – Adjust Belt Gap.....	9
Figure 11 – Verify Belt Gap.....	9
Figure 12 - Blower Rotations	10
Figure 13 - Remove Belt Guard	11
Figure 14 – Remove Belt.....	11
Figure 15 – Disconnect Water-Cooling Lines.....	11
Figure 16 – Remove Blower Head	11
Figure 17 – Move Water-Cooling Plugs	11
Figure 18 - Reinstall Blower Heads	11
Figure 19 – Reconnect Water-Cooling Lines	12
Figure 20 – Reinstall Belt.....	12
Figure 21 – Verify Belt Gap.....	12
Figure 22 - Adjust Belt Gap	12
Figure 23 - Motor Rotation Sticker	13
Figure 24 - Remove Belt Guard	20
Figure 25 - Install New Belt	20
Figure 26 - Set Belt Gap to 3/4 inch.....	20
Figure 27 - Adjust Gap	20
Figure 28 - Remove Belt Guard	21
Figure 29 - Remove Belt	21
Figure 30 – Verify Belt Gap.....	22
Figure 31 - Adjust Belt Gap	22

1 Sonic 300 / Sonic 300C

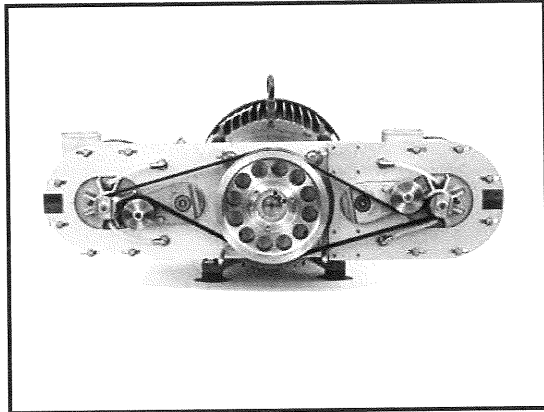

Figure 1 - Sonic 300C (Front View)

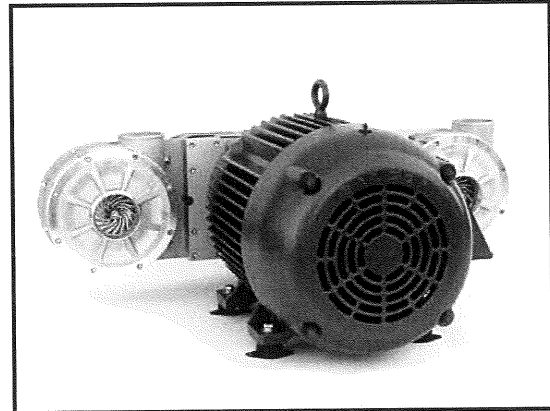

Figure 2 - Sonic 300C (Back View)

1.1 Introduction

Thank you for the recent purchase of a Sonic 300 or Sonic 300C centrifugal blower or retro-kit. Sonic Air Systems is confident that the blower unit is the best available in this performance range. Sonic manufactures blowers using the finest components available, assembles using only highly trained and qualified personnel, and inspects each unit 100% for quality and performance.

The following manual is intended to:

- Identify safety hazards
- Familiarize personnel with the equipment performance
- Demonstrate typical installation and usage
- Identify maintenance schedule and typical spare components
- Provide Sonics' Performance Guarantee and Warranty information

1.2 Blower Performance

- The Sonic 300 series blower is a single stage centrifugal blower and has been designed in accordance with fan engineering laws. Horsepower demand increases in proportion to increased air volume (motor amperage draw increases). As the air volume decreases (valve closes or filter clogs), the amp draw decreases. **Always check a fully installed system to ensure that the motor is not overloaded.**
- Sonic air blowers have some of the largest turndown ratios of any blower in their performance range. At 10:1, a Sonic 150 blower head's range is from 120 cfm (57 lps) to 1,200 cfm (566 lps) without overheating or surging. Outside of those ranges the air surging is mild and continuous operation may shorten the bearing life.
- The blower inlet must also be hose coupled to an inlet filter-silencer, inlet air safety screen or piped to a delivery system. Sonic inlet filter-silencers should be used in every application where the inlet air is not piped directly to the blower inlet. Sonic standard filters are rated at 2 microns with a paper element or 5 microns with a polyester element.

Inlet air temperature must not exceed 125°F (52°C) unless a Sonic 300C water-cooled unit is used. If the blower is in an enclosed space and the inlet air is piped from another area, make sure that the ambient temperature around the blower / motor does not exceed 110°F (43°C). When air is re-circulated from an air knife zone, in-line filters and water separators must be used to prevent water from entering the blower.

- The blower outlet must always be hose coupled to a discharge silencer, system piping, or otherwise directed away from personnel. Discharged air should be silenced to levels as required by applicable occupational safety standards or corporate standards as applicable. In order to minimize pressure drop and noise transmission, Sonic recommends using smooth bore tubing (hard plastic or metal).
- Flex hose can induce a large pressure drop and should only be used when absolutely necessary. Flex hose should be rated to handle a pressure of 10 psig (0.7 bar) at 200°F (93°C). Flex hose can be used for connecting misaligned piping and bend radii that do not match standard elbows. Be aware that flex hose can collapse inside and should be inspected if flow problems occur. Short rubber sleeves with band clamps are standard for blower and piping connections.
- Sonic butterfly valves have a wafer design that is designed to regulate flow, but will not seal when closed. Air will always leak around the wafer to help minimize blower cavitations.
- The Patent Pending Sonic Belt Tensioner is used to maintain a constant low tension on the drive belt and reduces the maintenance schedule for the blower unit. Belt life is optimized and belt replacement typically takes only 5 to 10 minutes to perform.
- Typical blower noise is approximately 80db to 95db. Sonic Blower Acoustical Enclosures can be used to reduce blower noise to within 75 db to 85 db depending on the blower model. Additional noise reduction is available; contact Sonic for details.

1.3 Product Profile

The Sonic 300 centrifugal blower package integrates two Sonic 150 blower heads to allow for high airflows (up to 2,400 scfm (1,132 lps)) while maintaining the pressure/vacuum performance of any individual Sonic 150 blower. The dual belt drive consists of two motor pulleys, two identical belts and the blower pulleys. The controlled motor pulley's position is relative to the bracket, which allows for proper alignment with blower pulleys. The Automatic Belt Tensioner does not require regular belt maintenance, which eliminates periodic belt adjustments. The head assemblies can be powered by one 30-50 HP (22-37 kW) motor. Blower package performance ranges from 240-2,400 scfm (114-1,132 lps) at 10-130" H₂O (4.0 PSIG or .28 bar) pressure or vacuum. The two blowers can be connected through a common manifold or through individual manifolds.

Note: The Sonic 300 is not designed for series (two stage) operation; consult Sonic for high pressure or vacuum requirements.



1.4 Typical Applications

The following is a list of typical applications for using a Sonic 300 centrifugal blower assembly. This is only a partial list of the possible uses for supplying low cost, clean air to a particular application. Please consult a Sonic Application engineer to design a system to meet any request.

Parts drying	Engine exhaust sampling
Hydrocarbon vapor recovery	Environmental test chambers
Gas boosting	Tank / Pond aeration
Concrete grinding vacuum	Gas meter testing
Cooling	Vacuum hold down
Oil spill containment booms	Air bearings

Special applications and options are available for the Sonic 300 blower unit:

Corrosion resistant electroplating	Air flow control valves
316 Stainless Steel Material Option	Acoustical enclosure
Welded inlet and outlet flanges	In-Line filters and water separators
Water cooling of the bearing housing	Filter Silencers
Operation to 400°F inlet air temperature	Explosion Proof motors
Thermocouple monitoring of bearings	Wash Down duty motors
Discharge silencers	Premium Efficiency (PE) motors
IEC motor compatibility	Hydraulic motors

Sonic also provides a full line of air / gas handling accessories:

Complete drying systems	Air wipe collars
Air blowers from 3 to 50 horsepower	HEPA filters to 1,000 CFM
High efficiency aluminum air knives	Acoustical enclosures
High efficiency stainless steel air knives	Piping accessories

Sonic services four main industries:

Food and Beverage	Wire and Cable
Electronics	Metal and Sheet Fabricators

Please contact a local Sonic representative or a Sonic application engineer to discuss any special considerations or applications.

2 Initial Inspection

Upon receipt of your Sonic Air Centrifugal Blower, make sure that all components listed on the packing slip are present. Check to see that the serial number on the blower housing matches the packing slip (See Figure 4). Inspect the blower / motor to ensure that they are mounted with the correct outlet position and that the motor is the correct horsepower, voltage and enclosure. If you have any shortages, discrepancies, or shipping damage, please call your Sonic Distributor or Sonic Air Systems immediately.



Figure 3 - Sonic Nameplate

The serial number of the blower identifies the blower model, pulley size, belt size, mounting position, and the motor specifications. Please use this number for any correspondence with the Sales / Customer Service Department at Sonic Air Systems.

Blower Serial Number	
-----------------------------	--

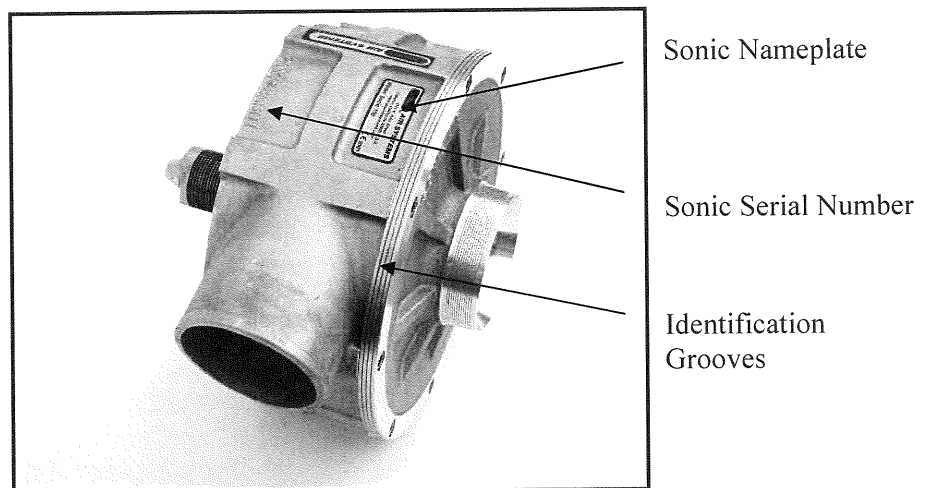

Figure 4 – Blower Serial Number

3 Safety Instructions

3.1 Electrical

- Always use qualified electrical and mechanical personnel for installation and maintenance of Sonic air blowers.
- No work should be performed on a Sonic air blower until the power has been turned off and an isolation device has been applied. Disconnect the electrical power at the motor starter, fuse box, or circuit breaker before working on the blower / motor. Double check to be sure that the power is off and that it cannot be turned on while you are working on the blower / motor assembly.
- Use proper electrical installation, wiring, and controls consistent with local and national electrical codes. A lockable isolation switch should be provided.
- Refer to the motor nameplate data for the proper power supply requirements. Be sure the junction box connections are tight and well insulated to prevent shorts and to assure maximum protection against moisture.



3.2 Mechanical

- Never run the Sonic air blower without the belt guard installed.
- Never run the Sonic air blower with the outlet open to atmosphere as this can cause the motor to overload.
- Never run the Sonic air blower with the inlet open to atmosphere. Always connect your system piping, Sonic inlet filter, or Sonic Inlet safety screen to the blower inlet to prevent personal injury or damage to the blower.
- Keep tools, clothing and hands away from rotating or moving parts while the unit is running.
- Use safety glasses when working around the blower / motor and / or air knife assembly while the system is running.
- Always use proper lifting techniques and equipment.
- Observe good safety habits at all times and use care to avoid injury to personnel and damage to the equipment.

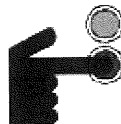

4 Installation and Adjustments

The following steps and procedures detail the installation and setup of a typical blower assembly. Disassembly of a blower unit is the opposite of the assembly procedure.

4.1 Lifting and Handling

Due to the weight of the blower / motor assembly, it should be lifted by a hoist or forklift using the single eyebolt on the top middle of the motor. See Section 6.1 - Component Specification Sheet for weight and dimension details.

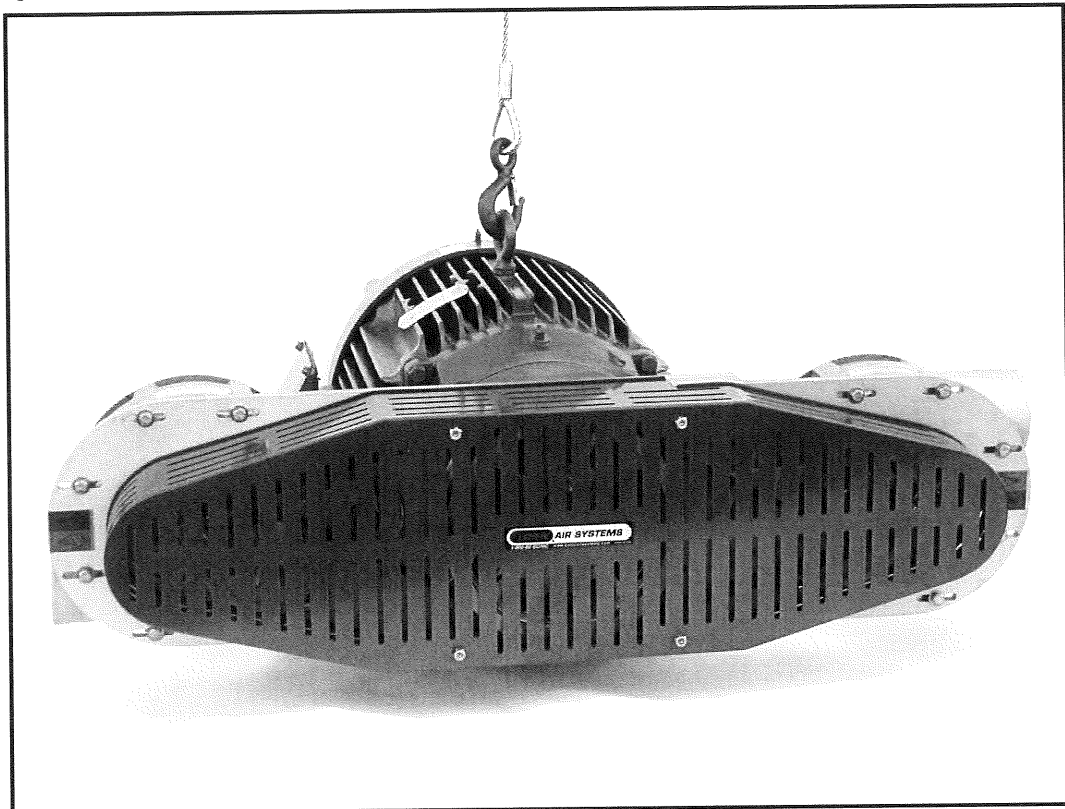

Figure 5 - Lifting Point

4.2 Blower Location

4.2.1 Access

Make certain to allow room for proper ventilation and accessibility to remove the belt guard for belt replacement as well as filter servicing. Never block the ventilation holes in the belt guard. Mount the blower / motor assembly in a well ventilated area to prevent motor overheating and premature belt and / or blower head failure.

4.2.2 Temperature

The blower / motor assembly must be placed in an area that prevents hard freezes or overheating. Ambient temperature conditions should range from a low of +10°F (-12°C) to +110°F (43°C). The blower / motor assembly is suitable for outdoor locations, but care should be taken to protect the equipment from temperature extremes, direct exposure to the sun, rain, snow, and dust so as to extend the service life of the blower, motor, and filter.

The blower / motor assembly, while running, can increase the ambient temperature above 110°F (43°C). Always check the running ambient temperature and do not operate above 110° (43°C).

4.2.3 Moisture and Debris

Sonic air blowers have a high-speed belt drive, close tolerance components and precision bearings. Do not put the blower where it will be sprayed from a washing / rinsing zone, from over-spray from an air knife or where dust, dirt, or other debris will attack the drive belt or clog the filter. If the filter needs cleaning or replacing more than one time each month, the blower or filter should be moved to a cleaner, dryer area. A Sonic acoustical blower enclosure will also ensure safe operation.

4.2.4 Wash Down

In factory locations subject to high-pressure water or caustic wash down cycles, the blower / motor unit must be protected or relocated to prevent damage. Raising the blower 1-2 feet (0.3 to 0.6 meters) above the wash zone is recommended. Wash down duty motors and corrosive resistant blower coatings are available to allow full exposure should it be needed.

4.2.5 Explosive Environments

The Sonic 300 centrifugal blower is made from non-sparking aluminum and therefore is suitable for explosive gases and explosive environments. Special explosion proof motors can also be included for hazardous duty.

4.2.6 Corrosive Environments

The Sonic 300 blower can be protected with special coatings for protection in corrosive environments. Protection level and life of blower is dependent on type of chemical and the concentration level.

4.2.7 Vibration

Due to the low vibration level of the Sonic air blowers, they can be bolted to any type of foundation or framework without transmitting any significant vibration. Sonic provides four rubber isolation mounts on most assemblies to prevent other equipment vibration from damaging the blower bearings.

4.2.8 Water Cooling Circuit

If the inlet air / gas is piped directly to the blower inlet, and the temperature is over 125°F (52°C), a water-cooled blower head must be used to protect the shaft bearings. The exact water temperature and flow required in the cooling circuit

will vary with each blower configuration and application. Although water demand for the blower head varies, the common design point in all applications is that the water exiting from the cooling circuit should never exceed 100°F (38°C). Typical water demand per head will range from ¼ to ¾ gallons per minute (1 to 3 liters per minute) if using tap water (approximately 65°F (18°C)) and will be significantly lower if chilled water is used.

4.2.9 Thermocouple Option

All Sonic 150 blower heads can be ordered with a thermocouple option. The thermocouple is in direct contact with the shaft bearing and continuously monitors the temperature of the bearing. Continuous monitoring of the blower head bearing temperature can indicate an imminent bearing failure (See Section 12 for Sonics’ repair policy). Predicting and anticipating a bearing failure may save costly equipment and / or line down time.

4.3 Belt Installation

Sonic ships all new systems with the drive belt removed. This is to assure that the electrical starter, soft start and wiring is correct before the blower is started. See Section 5.1 for motor wiring instructions and verify that the wiring and blower rotation is correct before installation of the drive belt.

4.3.1 Tools Required

Description	Qty.
½ inch box-end wrench	1
9/16 inch box-end wrench	1

Description	Qty.
Rubber Mallet (optional)	1

4.3.2 Belt Installation Procedure

1. Remove the belt guard using the ½ inch box-end wrench. (See Figure 6)
2. Using the 9/16 inch box-end wrench, rotate the belt tensioner arm counter clockwise (CCW). At the same time wrap the belt around the blower pulley, then along the right side of the idler pulley, and finally around the motor pulley. (See Figure 7 & Figure 9)
3. Slowly rotate the motor pulley to make sure the belt is seated in the grooves.
4. Verify that the belt gap is approximately ¾ inch ±1/16 inch (Factory Set). (See Figure 11)
5. If a ¾ inch belt gap was not achieved, use a ½ inch box-end wrench to loosen the blower head screws and slide the head. (See Figure 8 and Figure 10)
6. Using the ½ inch box-end wrench, reinstall the belt guard.

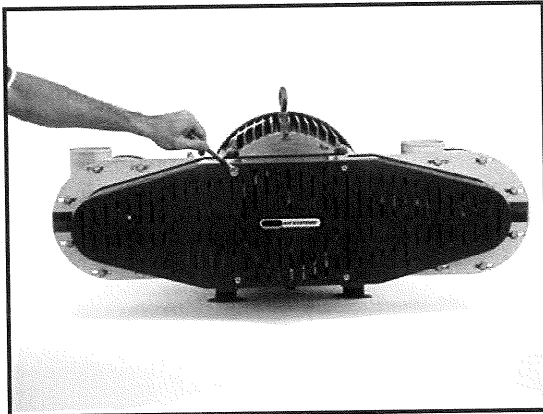

Figure 6 - Remove Belt Guard

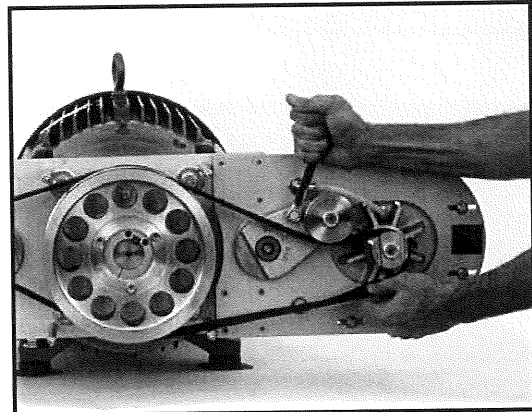

Figure 9 - Install Belt

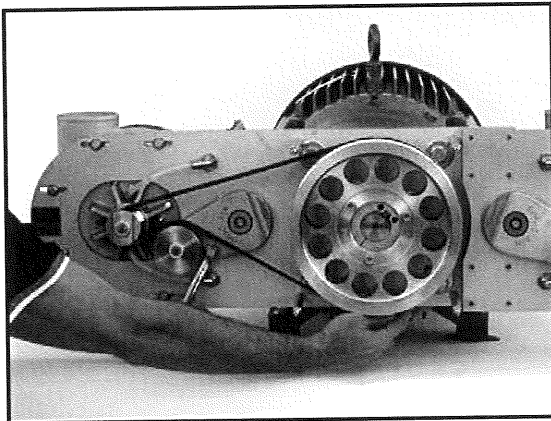

Figure 7 - Install Belt

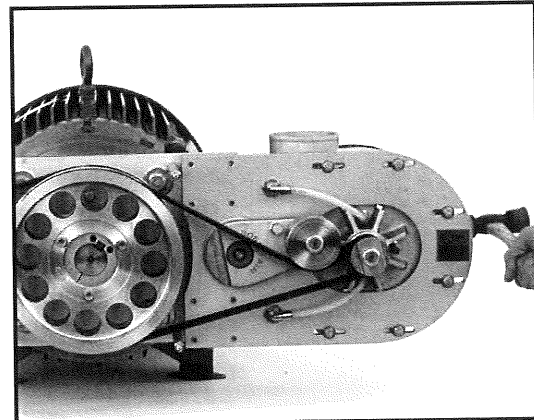

Figure 10 - Adjust Belt Gap

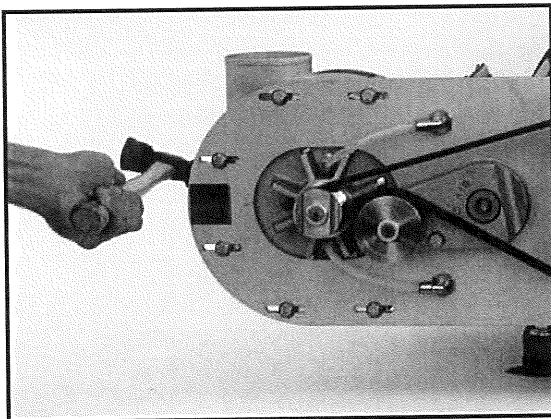

Figure 8 - Adjust Belt Gap

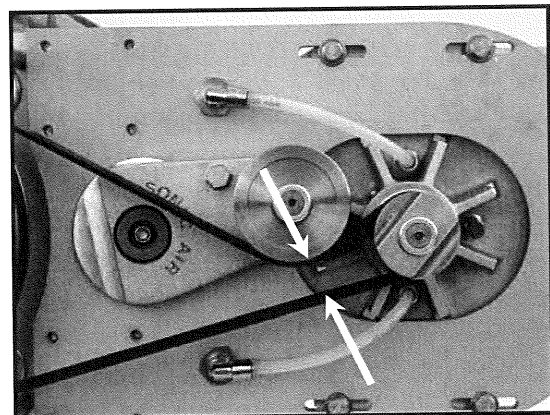

Figure 11 - Verify Belt Gap

4.4 Blower Head Mounting Adjustment

The blower head position was adjusted at the factory to the application specifications. Therefore, it should not be necessary to change the position of the blower head outlet unless the application specifications have changed or the unit is relocated. See Figure 12

for blower head rotation options. Use the following procedure to modify or adjust the blower head rotation.

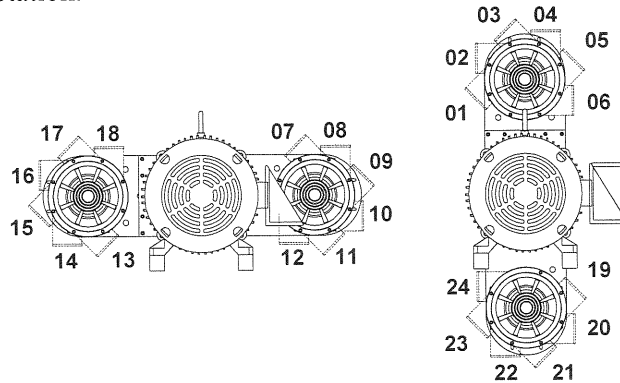

Figure 12 - Blower Rotations

4.4.1 Required Tools

Description	Qty.	Description	Qty.
½ inch box-end wrench	1	Rubber Mallet (optional)	1
9/16 inch box-end wrench	1	½ inch socket	1
3/8 inch ratchet driver	1		

4.4.2 Blower Head Adjustment Procedure

1. Remove the belt guard using the ½ inch box-end wrench. (See Figure 13)
2. Using the 9/16 inch box-end wrench, rotate the belt tensioner arm counter clockwise (CCW) and remove the belt. (See Figure 14)
3. Disconnect the water-cooling lines at the quick disconnect on the blower head. (See Figure 15) (If Applicable)
4. Using the ½ inch box-end wrench, remove the eight screws from the bracket that secure the blower head. (See Figure 16)
5. Remove the water-cooling plugs from the blower head and rotate as necessary. (See Figure 17)(If Applicable)
6. Rotate the blower head to desired rotation and reinstall the eight screws to the proper torque specifications. (See Section 7.2 - Torque Specifications) (See Figure 18)
7. Reinstall the water-cooling lines. (See Figure 19) (If Applicable)
8. Using the 9/16 inch box-end wrench, rotate the belt tensioner arm counter clockwise (CCW). At the same time wrap the belt around the blower pulley, then along the right side of the idler pulley, and finally around the motor pulley. (See Figure 20)
9. Slowly rotate the motor pulley to make sure the belt is seated in the grooves.
10. Verify that the belt gap is approximately ¾ inch ±1/16 inch. (See Figure 21)
11. If a ¾ inch belt gap was not achieved, use a ½ inch socket to loosen the blower head screws and slide the head. (See Figure 22)
12. Using the ½ inch box-end wrench, reinstall the belt guard.

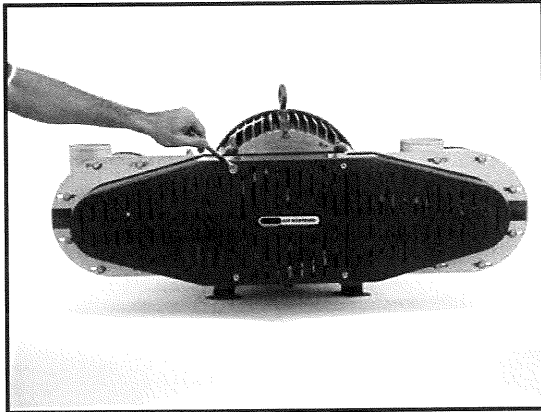

Figure 13 - Remove Belt Guard

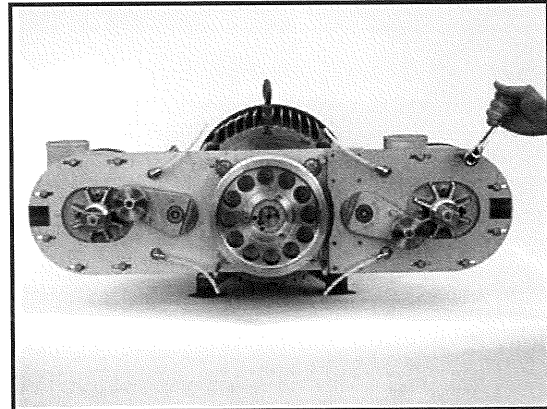

Figure 16 – Remove Blower Head

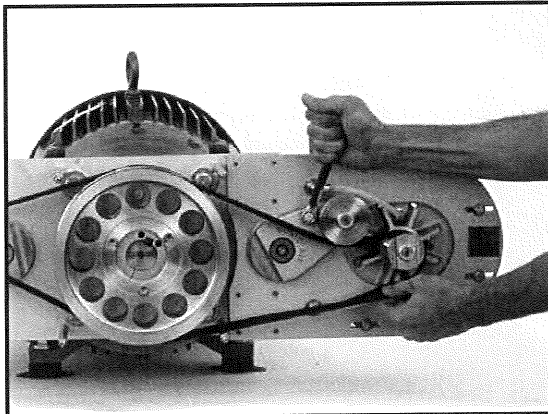

Figure 14 – Remove Belt

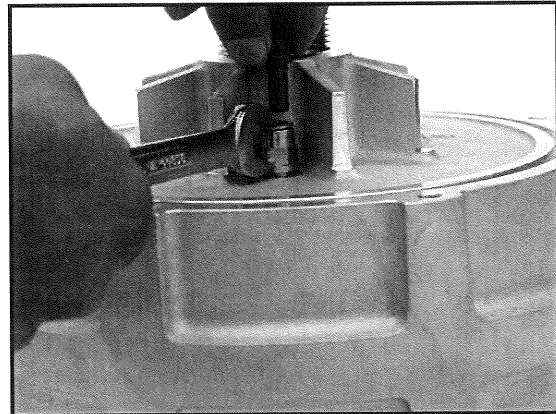

Figure 17 – Move Water-Cooling Plugs

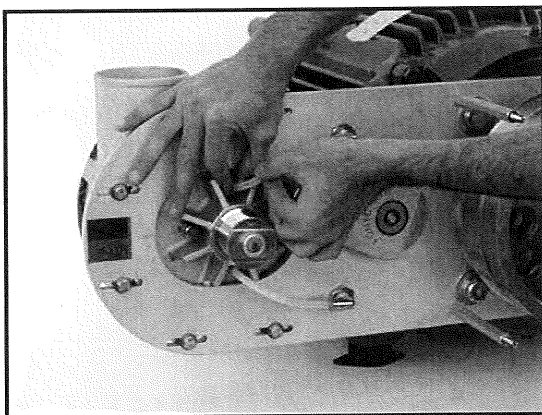

Figure 15 – Disconnect Water-Cooling Lines

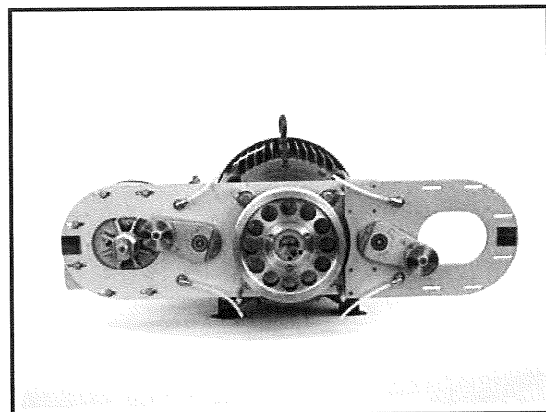

Figure 18 - Reinstall Blower Heads

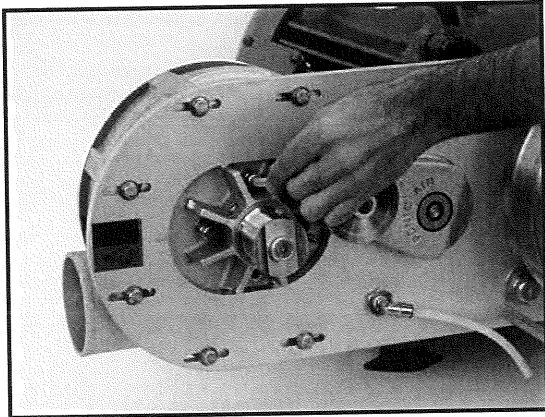

Figure 19 – Reconnect Water-Cooling Lines

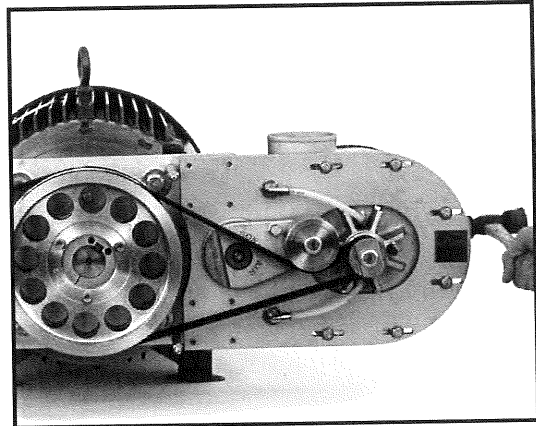

Figure 22 - Adjust Belt Gap

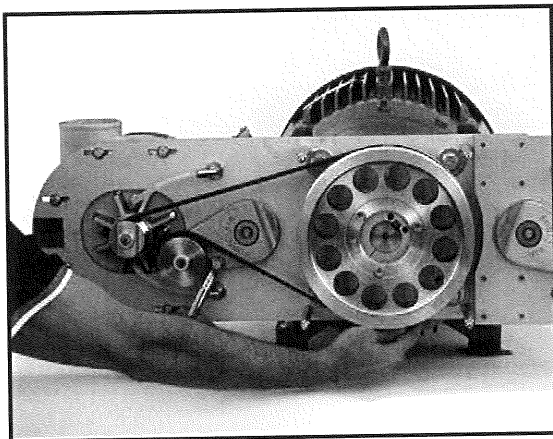

Figure 20 – Reinstall Belt

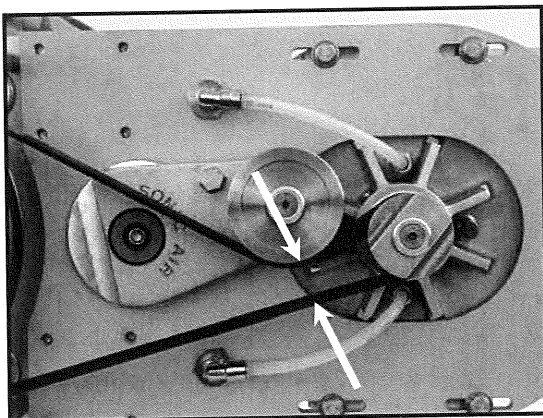

Figure 21 – Verify Belt Gap

5 Electrical Wiring, and Start-Up

5.1 Motor Wiring

- Only qualified personnel should perform motor wiring. Review motor nameplate for wiring diagram and wiring information. Many Sonic motors are dual rated for 50 and 60 hertz operation and therefore will have two nameplates. Every motor is supplied with a sticker indicating the hertz set up of the blower unit.

50 HZ

60 HZ

- Never run a Sonic blower open to the atmosphere as this can cause overloading and damage to the motor.
- All Sonic blowers must rotate clockwise (CW) when viewing the pulley or counter clockwise (CCW) when viewing the cooling fan end of the motor. See the arrow mounted on the motor housing for direction of rotation.



- Sonic blowers are shipped with the drive belt removed. This is because the motor rotation should be checked before installing the belt. Running the blower / motor assembly backwards will cause the blower to under perform by 20%. Running backwards for prolonged periods will cause premature failure of the belts and permanent damage to the belt tensioner assembly. Refer to the Motor Rotation Sticker located on the mounting bracket for correct motor rotation and belt installation. (See Figure 23)

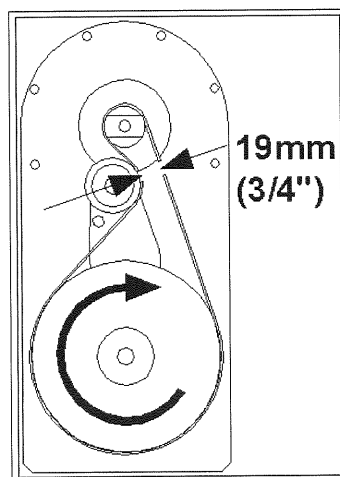
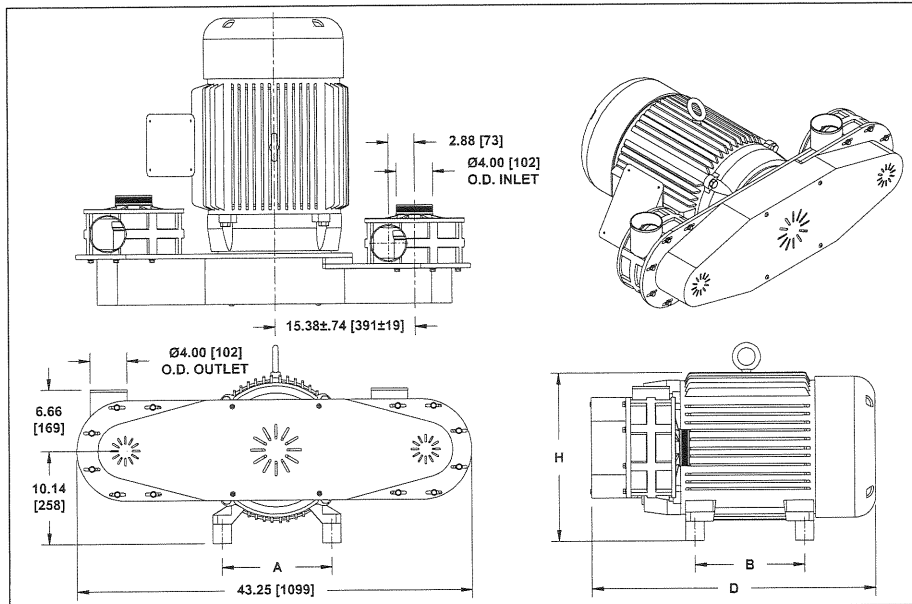

Figure 23 - Motor Rotation Sticker

6 Blower Specifications

6.1 Blower Specification Sheet



Component Specifications

Description	Blower – Sonic 300			Blower –Sonic 300 Water Cooled		
	19715	19723	19738	19741	19759	19764
Sonic P/N	19715	19723	19738	19741	19759	19764
Output Flow Rate	1,200 cfm (567 lps) to 2,400 cfm (1,133 lps)			1,200 cfm (567 lps) to 2,400 cfm (1,132 lps)		
Ambient Temperature	10°F (-12°C) to 105°F (40°C)			10°F (-12°C) to 105°F (40°C)		
Air Temperature Range	< 125°F (52°C)			125°F (52°C) to 400°F (205°C)		
Motors Available	30 Hp	40 Hp	50 Hp	30 Hp	40 Hp	50 Hp
Depth (D)	28.13 in (715 mm)	31.13 in (791 mm)	31.13 in (791 mm)	28.13 in (715 mm)	31.13 in (791 mm)	31.13 in (791 mm)
Height (H)	16.19 in (412 mm)	21.38 in (543 mm)	21.38 in (543 mm)	16.19 in (412 mm)	21.38 in (543 mm)	21.38 in (543 mm)
Mounting Pattern (A)	11.0 in (280 mm)	12.5 in (318 mm)	12.5 in (318 mm)	11.0 in (280 mm)	12.5 in (318 mm)	12.5 in (318 mm)
Mounting Pattern (B)	11.0 in (280 mm)	12.0 in (305 mm)	12.0 in (305 mm)	11.0 in (280 mm)	12.0 in (305 mm)	12.0 in (305 mm)
Approximate Weight	493 lb (224 kg)	605 lb (275 kg)	713 lb (324 kg)	493 lb (224 kg)	605 lb (275 kg)	713 lb (324 kg)
Replacement Belt P/N	13451	13451	13451	13451	13451	13451

6.2 Assembly Drawing

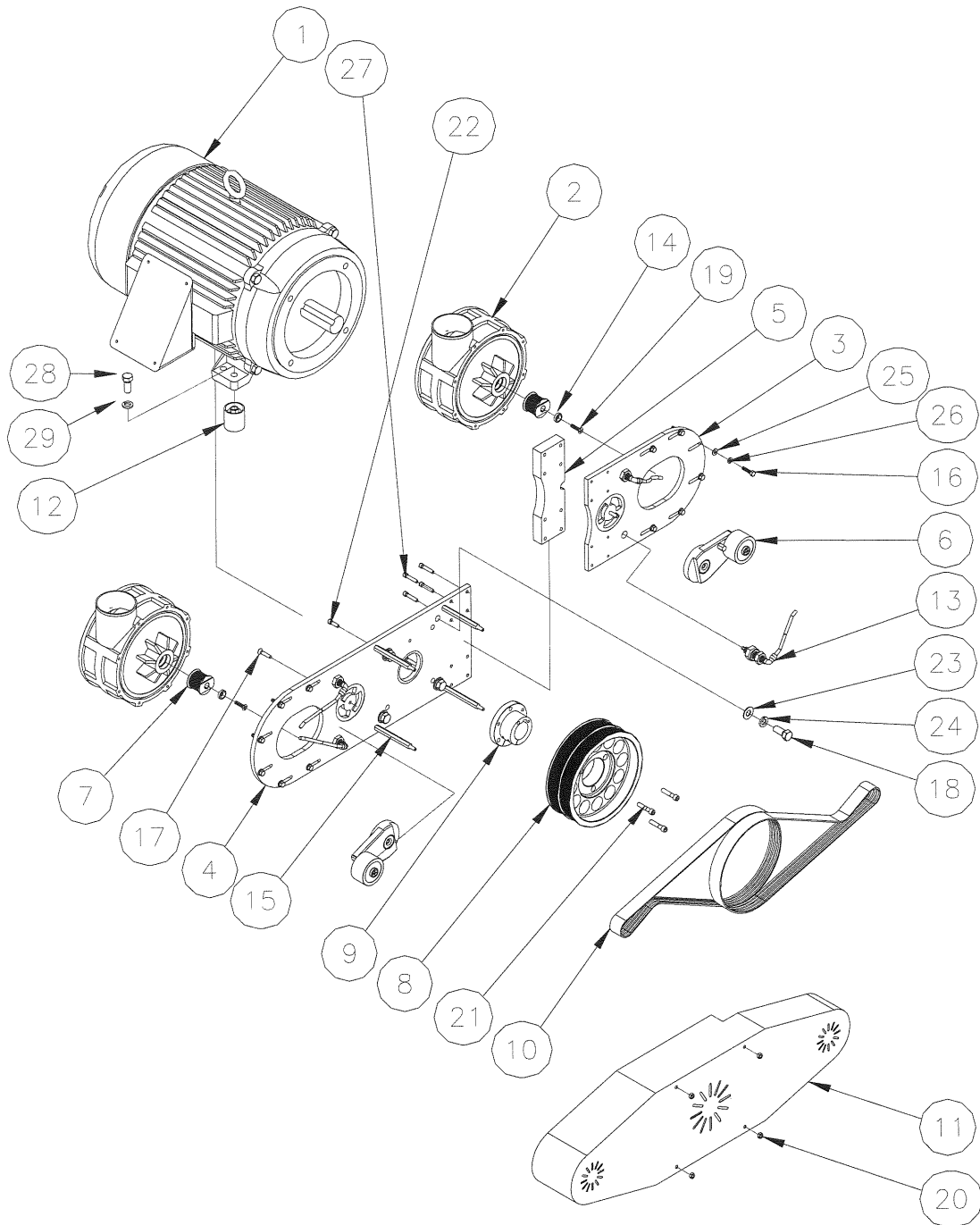

6.3 Parts List

6.3.1 Sonic 300 Blower Unit

Item No.	Part No.	Description	Qty.
1	Section 6.4.1	Motor, Electric	1
2	19213	Blower Head, Sonic 150	2
3	13459	Bracket, Sonic 200/300 16.25"	1
4	12418	Bracket, Sonic 200/300 30.25"	1
5	13454	Bracket, Sonic 200/300 Joining	1
6	13455	Belt Tensioner Assembly	2
7	13450	Pulley, Blower	2
8	13597	Pulley, Motor	1
9	12625	Bushing Kit	1
10	13451	Belt	2
11	13453	Belt Guard	1
12	12548	Vibration Isolators	4
13		(Not Required)	
14	10679	Retainer, Pulley	2
15	13507	Standoff Assembly	4
16	12540	Screw, 5/16-18 x 1.25 Lg., HHS SS	12
17	12340	Screw, 5/16-18 x 1.5 Lg., FHS SS	2
18	10759	Screw, 1/2-13 x 1.5 Lg., HHS Plated (30 HP Only)	4
18a	12538	Screw, 5/8-11 x 1.5 Lg., HHS Plated (40 & 50 HP Only)	4
19	13482	Screw, 5/16-24 x 1.0 Lg. FHS SS	2
20	12342	Nut, 5/16-18 Hex SS w/ Nylock	4
21		Screw, 3/8-16 x 1.75 Lg., SHCS (See Bushing Kit)	3
22	10454	Screw, 5/16-18 x 1.0 Lg., SHCS SS	4
23	10263	Washer, 1/2" Plated (30 HP Only)	4
23a	12573	Washer, 5/8" Plated (40 & 50 HP Only)	4
24	12364	Lock Washer, 1/2" Plated (30 HP Only)	4
24a	12539	Lock Washer, 5/8" Plated (40 & 50 HP Only)	4
25	12543	Washer, 5/16" SS	12
26	12542	Lock Washer, 5/16" SS	12
27	13476	Screw, 5/16-18 x 1.75 Lg., SHCS SS	8
28	10759	Screw, 1/2-13 x 1.5 Lg., HHS Plated	4
29	12364	Lock Washer, 1/2" Plated	4

6.3.2 Sonic 300C Blower Unit

Item No.	Part No.	Description	Qty.
1	Section 6.4.1	Motor, Electric	1
2	19225	Blower Head, Sonic 150C	2
3	13459	Bracket, Sonic 200/300 16.25"	1
4	12418	Bracket, Sonic 200/300 30.25"	1
5	13454	Bracket, Sonic 200/300 Joining	1
6	13455	Belt Tensioner Assembly	2
7	13450	Pulley, Blower	2
8	13597	Pulley, Motor	1
9	12625	Bushing Kit	1
10	13451	Belt	2
11	13453	Belt Guard	1
12	12548	Vibration Isolators	4
13		Feed-Thru Assembly, Water-Cooled	4
14	10679	Retainer, Pulley	2
15	13507	Standoff Assembly	4
16	12540	Screw, 5/16-18 x 1.25 Lg., HHS SS	12
17	12340	Screw, 5/16-18 x 1.5 Lg., FHS SS	2
18	10759	Screw, ½-13 x 1.5 Lg., HHS Plated (30 HP Only)	4
18a	12538	Screw, 5/8-11 x 1.5 Lg., HHS Plated (40 & 50 HP Only)	4
19	13482	Screw, 5/16-24 x 1.0 Lg. FHS SS	2
20	12342	Nut, 5/16-18 Hex SS w/ Nylock	4
21		Screw, 3/8-16 x 1.75 Lg., SHCS (See Bushing Kit)	3
22	10454	Screw, 5/16-18 x 1.0 Lg., SHCS SS	4
23	10263	Washer, ½" Plated (30 HP Only)	4
23a	12573	Washer, 5/8" Plated (40 & 50 HP Only)	4
24	12364	Lock Washer, ½" Plated (30 HP Only)	4
24a	12539	Lock Washer, 5/8" Plated (40 & 50 HP Only)	4
25	12543	Washer, 5/16" SS	12
26	12542	Lock Washer, 5/16" SS	12
27	13476	Screw, 5/16-18 x 1.75 Lg., SHCS SS	8
28	10759	Screw, ½-13 x 1.5 Lg., HHS Plated	4
29	12364	Lock Washer, ½" Plated	4



6.4 Motor / Bushing Cross Reference

6.4.1 Nema Motor Specifications

Baldor Motor Specifications

HP	Part No.	Weight	Hertz (Standard)	Voltage (Standard)	Full Load Amps	RPM
30 hp (22 kW)	12701	383 lbs (174 kg)	60	230 / 460	70 / 35	3500
40 hp (30 kW)	12698	486 lbs (221 kg)	60	230 / 460	90 / 45	3500
50 hp (37 kW)	12822	595 lbs (270 kg)	60	230 / 460	112 / 56	3500

US Electric Motor Specifications

HP	Part No.	Weight	Hertz (Standard)	Voltage (Standard)	Full Load Amps	RPM
30 hp (22 kW)	12524	390 lbs (177 kg)	50 / 60	230 / 460 190 / 380	70 / 35 88 / 44	3500 2850
40 hp (30 kW)	12525	460 lbs (209 kg)	50 / 60	230 / 460 190 / 380	92 / 46 115 / 57	3500 2850
50 hp (37 kW)	12827	590 lbs (268 kg)	50 / 60	230 / 460 190 / 380	112 / 56 140 / 70	3500 2850

All standard Sonic supplied motors are equipped with C-face, foot mounted, and are for 3 phase power only. Special motors are available from Sonic Air Systems and are not included in the above table.

7 Periodic Maintenance

7.1 Maintenance Schedule

Sonic 300 series blowers are designed for 24 hour / 365 day operation with periodic service and / or replacement of the belts and filters.

The following inspection and service intervals are listed as hours of operation or elapsed time from blower installation, whichever comes first. It is always preferable to perform maintenance earlier than recommended, especially in hot, cold, wet, dirty, or otherwise hostile environments.

Inspection or Task	Frequency
Inspect belt for wear	3 Months / 1,000 Hours
Replace belt	12 Months / 4,000 Hours
Inspect belt tensioner	3 Months / 1,000 Hours
Replace belt tensioner	3 Years / 12,000 Hours
Inspect filter / Replace or Clean filter element	Monthly
Inspect motor and grease bearings	12 Months / 4,000 Hours
Replace motor	5 Years / 20,000 Hours
Blower head bearings	Sealed – No Service Required
Replace blower head	3 Years / 12,000 Hours
Inspect blower and motor pulley	3 Months / 1,000 Hours
Inspect hardware torque	12 Months / 4,000 Hours

7.2 Torque Specifications

Bolt Description	Recommended Torque Value
5/16-18 HHS or SHCS	25 ft-lbs (34 N-m)
5/16-24 HHS or SHCS	20 ft-lbs (27 N-m)
3/8-16 HHS or SHCS	30 ft-lbs (41 N-m)
½-13 HHS	45 ft-lbs (61 N-m)
5/8-11 HHS	60 ft-lbs (81 N-m)

7.3 Belt Replacement Procedure

7.3.1 Tools Required

Description	Qty.	Description	Qty.
9/16 inch box-end wrench	1	½ inch box-end wrench	1
Rubber mallet (optional)	1		

7.3.2 Belt Replacement Procedure

1. Remove the belt guard using the ½ inch box-end wrench. (See Figure 24)
2. Using the 9/16 inch box-end wrench, rotate the belt tensioner arm counter clockwise (CCW) and remove the belt.
3. Clean any belt debris or dust from blower and pulleys. Do not use any abrasive materials on the pulley grooves as this will damage the grooves and cause subsequent belt failures.

4. Using the 9/16 inch box-end wrench, rotate the belt tensioner arm counter clockwise (CCW). At the same time wrap the belt around the blower pulley, then along the right side of the idler pulley, and finally around the motor pulley. (See Figure 25)
5. Slowly rotate the motor pulley to make sure the belt is seated in the grooves.
6. Verify that the belt gap is approximately $\frac{3}{4}$ inch $\pm 1/16$ inch (Factory Set). (See Figure 26)
7. If a $\frac{3}{4}$ inch belt gap was not achieved, use a $\frac{1}{2}$ inch box-end wrench to loosen the blower head screws and slide the head. (See Figure 27)(See Section 7.2 - Torque Specifications)
8. Using the $\frac{1}{2}$ inch box-end wrench, reinstall the belt guard.

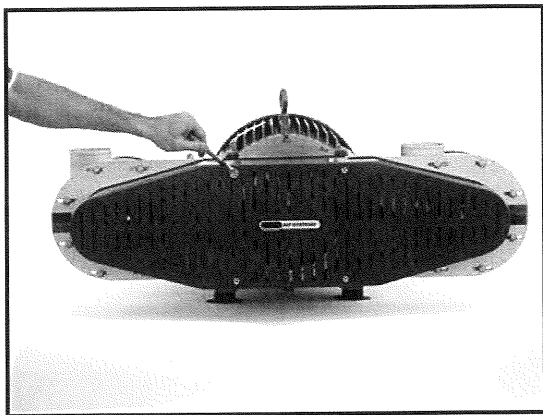

Figure 24 - Remove Belt Guard

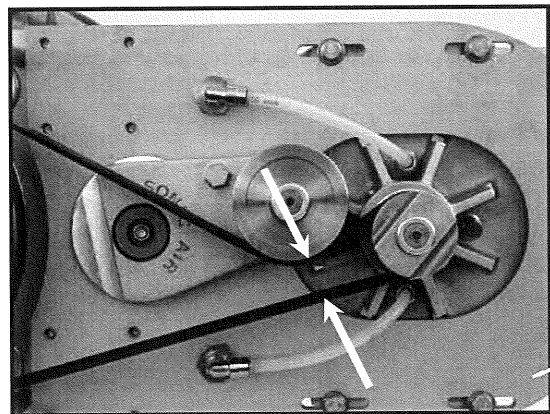

Figure 26 - Set Belt Gap to $\frac{3}{4}$ inch

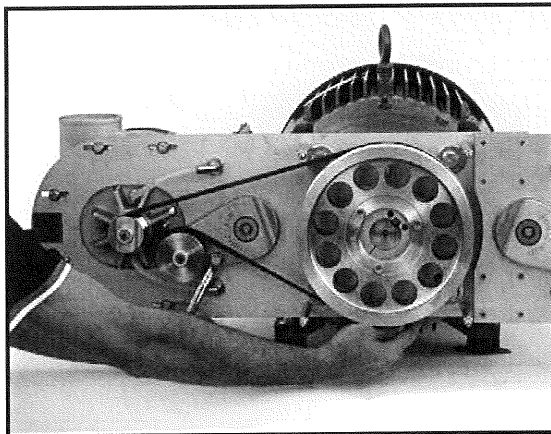

Figure 25 - Install New Belt

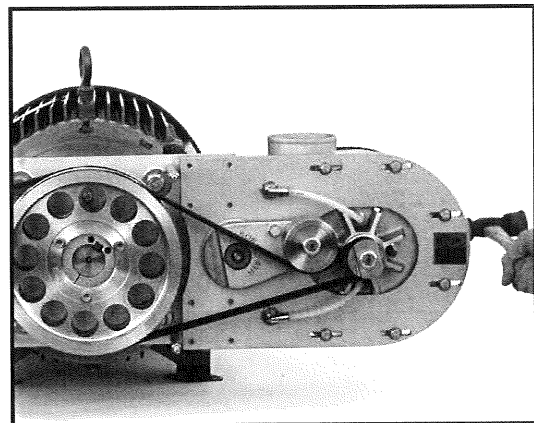

Figure 27 - Adjust Gap

7.4 Belt Tensioner Service

7.4.1 Tools Required

Description	Qty.
½ inch box-end wrench	1
9/16 inch box end wrench	1

Description	Qty.
3/16 inch allen wrench	1
Rubber mallet (optional)	1

7.4.2 Belt Tensioner Service Procedure

1. Remove the belt guard using the ½ inch box-end wrench. (See Figure 28)
2. Using the 9/16 inch box-end wrench, rotate the belt tensioner arm counter clockwise (CCW) and remove the belt. (See Figure 29)
3. Using the 3/16 inch allen wrench, secure the flat head screw from the back of the bracket while loosening the nylon-insert locknut with a ½ inch socket. This will allow the removal of the belt tensioner.
4. **Caution:** After removing belt tensioner, the compression springs will be exposed. Remove these springs temporarily if the new belt tensioner is not installed immediately. Wear safety glasses to prevent potential eye injury.
5. At reassembly, the static position should be approximately 25 degrees to the right of blower pulley. Install a new nylon-insert locknut to 20 ft-lbs when installing the new belt tensioner.
6. Using the 9/16 inch box-end wrench, rotate the belt tensioner arm counter clockwise (CCW). At the same time wrap the belt around the blower pulley, then along the right side of the idler pulley, and finally around the motor pulley.
7. Slowly rotate the motor pulley to make sure the belt is seated in the grooves.
8. Verify that the belt gap is approximately ¾ inch ±1/16 inch (Factory Set). (See Figure 30)
9. If a ¾ inch belt gap was not achieved, use a ½ inch box-end wrench to loosen the blower head screws and slide the head. (See Figure 31)
10. Using the ½ inch box-end wrench, reinstall the belt guard.

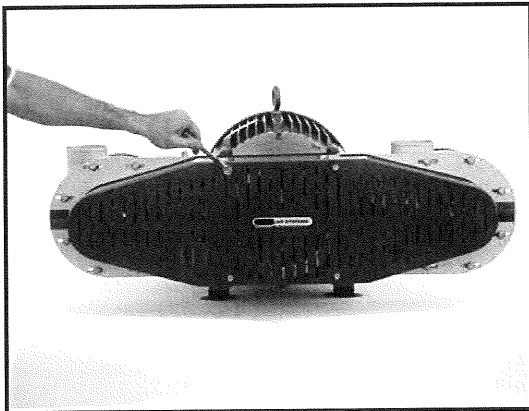

Figure 28 - Remove Belt Guard

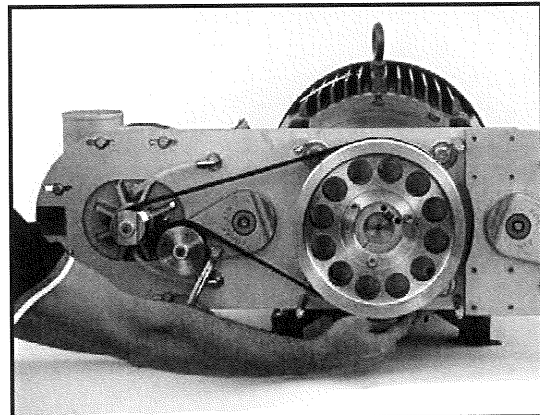

Figure 29 - Remove Belt

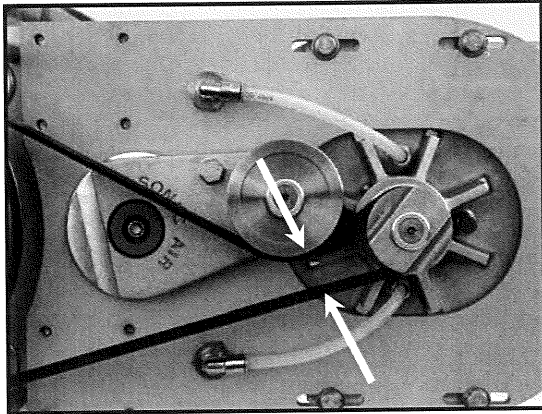

Figure 30 – Verify Belt Gap

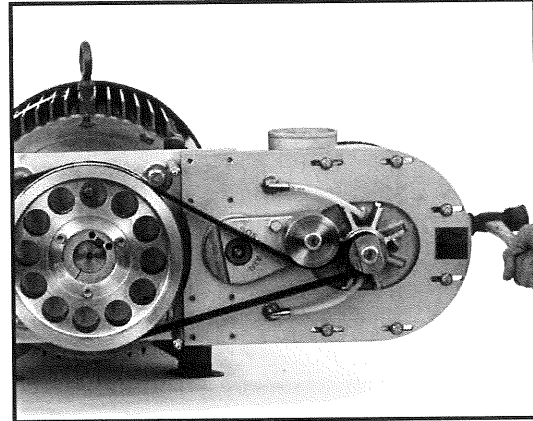

Figure 31 - Adjust Belt Gap



7.5 Recommended Spares

Although the Sonic 300 blowers are designed for many years of continued operation, a number of components are wear or consumable items and must be replaced periodically. The following is a list of recommended spare components that should be used to minimize equipment or line down time:

Part No.	Description	Recommended Qty.
19213	Sonic 150 Blower Head	1
19225	Sonic 150C Blower Head	1
13450-%%%	Pulley, Blower (16 Groove) (%%% Pulley Diameter, 1.55 to 2.20)	1
13597	Pulley, Motor (16 Groove)	1
13451	Belt, 52" Lg., 16 Groove	2
13455	Belt Tensioner Replacement Kit	1
10316	Filter Element, Paper	2
10317	Filter Element, Polyester	1
See Section 6.4	Motor	1

8 Troubleshooting

Trouble	Cause	Remedy	Section
Low Flow / Pressure / Vacuum	• Blower rotating backwards (Incorrect wiring)	• Reverse motor wiring	5.1
	• Dirty or contaminated filter	• Clean or replace filter element	7.1
	• Collapsed flexible hose lining	• Use only reinforced flexible hose	1.2
	• Air leaks in the system	• Fix leaks	4
	• Closed or damaged valve	• Open or replace valve	1.2
	• Worn or damaged impeller	• Replace impeller and inspect blower housing	7.1
	• Drive belt slipping (Contaminated or damaged)	• Replace belt	4.3, 7.3
		• Replace pulleys	7.1
		• Clean pulleys	7.1
	• Worn pulley	• Replace worn pulleys	7.1
	• Wrong pulley size	• Contact Sonic	Cover
	• Wrong drive belt (Not Sonic approved)	• Use only Sonic supplied belts	4.3, 7.3
	• Incorrect piping design (Too small)	• Increase piping diameter	4
	• Contact Sonic for design assistance	Cover	
	• Improper blower size for application	• Contact Sonic for design assistance	Cover
Frequent Drive Belt Failure	• Blower rotating backwards (Incorrect wiring)	• Reverse motor wiring	5.1
	• Motor pulley wobbling	• Replace motor	5.1, 7.1
		• Replace motor bushing	7.1
		• Replace motor pulley	7.1
	• Frequent start / stops without soft start controller	• Install soft start motor controller	5.1
		• Install diverter valve and run continuously	5.1
	• Motor pulley out of alignment	• Realign motor pulley	7.1
		• Replace mounting bracket if damaged	7.1
	• Pulley grooves worn	• Replace pulley	7.1
	• Hostile environment (belts contaminated)	• Locate blower in safe location	4.2
		• Purchase Sonic blower enclosure	4.2
	• Wrong belts (Not Sonic approved)	• Use only Sonic supplied belts	4.3, 7.3
	• Incorrect belt installation method	• Properly install belts	4.3, 7.3
• Worn belt tensioner	• Replace belt tensioner	7.1	
• Liquid entering blower inlet (impeller stall)	• Locate blower in safe location	4	
	• Install inline filters	4	
Electrical Overloading	• Exceeding rated CFM	• Contact Sonic	Cover
	• Blower RPM too high (Blower pulley too small)	• Contact Sonic	Cover
	• Motor has winding or bearing damage	• Replace motor	5.1
	• Electrical supply problems	• Replace drive controller	5.1
Thermocouple Alarm (Optional)	• High inlet temperature	• Purchase water cooled blower	4.2.8
		• Reduce inlet temperature	4.2.8
	• Dirty air filter	• Clean or replace filter element	7.1
	• High ambient temperature	• Purchase water cooled blower	4.2.8
	• Water cooling low flow	• Increase flow rate	4.2.8
		• Decrease water temperature	4.2.8
	• Blower speed too high	• Contact Sonic	Cover
• Broken belt (low temp)	• Replace belt	4.3, 7.3	
Irregular / Excessive Noise	• Blockage in air line	• Inspect plumbing and remove blockage	4
	• Leak in air line	• Repair leak	4
	• Inlet silencer damaged	• Replace filter / silencer	7.1
	• Worn drive belt	• Replace belt	4.3, 7.3
	• Bolts loose on blower / motor assembly	• Tighten bolts to proper torque specifications	7.2
	• Motor mounts loose	• Tighten bolts to proper torque specifications	7.2
	• Blower RPM too high	• Contact Sonic	Cover
	• Blower is receiving vibration from nearby equipment	• Install vibration isolators	4.2.7
		• Relocate blower assembly	4.2
Belt Jumping Off	• ¼ inch gap not set	• Adjust belt gap to ¼"	4.3, 7.3
	• Pulleys misaligned	• Realign motor pulley	7.1
		• Replace mounting bracket if damaged	7.1
	• Blower pulley wobbling	• Replace motor	5.1
		• Replace motor bushing	7.1
		• Replace motor pulley	7.1
	• High motor torque	• Replace motor with low torque equivalent	5.1
	• Blower rotating backwards (Incorrect wiring)	• Reverse motor wiring	5.1
• Belt not set in grooves properly	• Install belt correctly	4.3, 7.3	
• Wrong belt (Not Sonic approved)	• Install Sonic supplied belt	4.3, 7.3	

9 Performance Guarantee

Sonic Air Systems, Inc. (SAS) guarantees that each SAS supplied system will meet or exceed the designed level of performance. In the event the system does not achieve the designed performance, SAS will provide additional resources and equipment at no cost or refund 100% of the original purchase price.

- SAS must have quoted the system and supplied the system as quoted
- Buyer pays the original invoice within terms
- Buyer submits notification of system deficiency within 45 days of the original invoice date and allows SAS to remedy the deficiency
- Buyer must obtain written return authorization from SAS for any returns
- Buyer will return the system complete and in like new condition





10 Warranty Policy

Sonic Air Systems, Inc. (SAS) and its employees are proud of our products and are committed to providing our customers with quality, engineered products.

Scope of Warranty: All SAS designed products are warranted against defects in SAS design, workmanship and materials.

Warranty Period:

- Blower motor units are warranted for 18 months commencing on the invoice date from SAS
- Retro-kits and blower heads are warranted for 12 months commencing on the invoice date from SAS
- Repaired blower heads are warranted for 6 months commencing on the invoice date from SAS
- Accessories are warranted for 24 months commencing on the invoice date from SAS

Repairs Within the Scope of the Warranty: If a SAS designed product is defective and the defect occurs during the warranty period, SAS will either repair or replace, whichever SAS believes to be appropriate under the circumstances. SAS is not responsible for removal or reinstallation of product or any incidental or consequential damages resulting from the defect, removal, reinstallation, shipment, or otherwise.

Repairs Outside the Scope of the Warranty: Problems with SAS products can be due to faulty installation, misapplication, inadequate maintenance, non-SAS additions or modifications, or other problems not due to defects in SAS design, workmanship or materials. If SAS determines the warranty consideration is not due to defects in SAS design, workmanship or materials, the buyer will be responsible for the cost of any necessary repairs.

Procedure to Receive Warranty Service:

- Buyer obtains a written return authorization number from SAS
- The authorization number must be noted on the outside of the shipping container
- Buyer will ship F.O.B. destination freight prepaid to SAS factory
- Non-compliance to any of the above procedures, damage resulting from improper packaging, or product exposed to a hazardous substance may result in SAS refusing shipment
- International buyer, please contact SAS for the nearest authorized warranty center

Warranty exclusions:

- Motors shall be warranted under the respective manufacturer's policy
- Product with a tampered warranty seal
- Damage from fire, flood, theft, or vandalism
- Applications not approved by SAS which includes but not limited to product exposed to toxic, flammable, corrosive or other hazardous substance
- Damage resulting from installation or operational error
- Damage resulting from transportation carrier
- Belts, filter elements, or other similar service items
- Blower heads not repaired by factory authorized personnel

No Other Warranties and Liability Limitation:

THIS WARRANTY IS EXCLUSIVE AND IS IN LIEU OF ALL OTHER WARRANTIES WHETHER WRITTEN, ORAL OR IMPLIED. SAS' LIABILITY IN ALL CASES WILL BE LIMITED TO THE REPLACEMENT PRICE OF ITS PRODUCT. AT NO TIME SHALL SAS BE LIABLE FOR ANY COSTS TO THE BUYER FOR LABOR, TRANSPORTATION OR DOWNTIME RESULTING FROM EQUIPMENT FAILURES BY SAS OR OUR SUPPLIERS.



11 24/7/365 Service Program

Sonic Air Systems, Inc. (SAS) provides emergency product and shipping service, 24 hours a day, 7 days a week, 365 days a year, to all customers, worldwide. Shipments are made by Federal Express, UPS or UPS' Sonic Air Service or product may be picked up will-call at the SAS facility in Fullerton, CA USA. Simply call us at (714) 870-2700 during normal business hours or 7:30am to 4:30pm (Pacific Standard Time) for your immediate service needs. After hours number is (714) 473-3694.

- SAS charges Sonic list price to the buyer
- Distributor discounts and commissions are ineligible on this program
- All costs will be charged to the buyer's credit card (Master Card, Visa, or American Express, only) or to their previously established SAS credit line that is currently in good standing
- Payments made in US dollars only
- The cost for UPS' SonicAir Service is approximately \$500.00 for a 25 pound package for next flight delivery within the USA
- International shipments will take additional time due to import regulations within the country of destination
- UPS' SonicAir Service will attempt to have the product(s) clear international customs and import procedures, however, UPS cannot guarantee governmental acceptance
- SAS return authorization procedures and policies apply



12 Sonic Repair Policy

Sonic blower heads are high-speed close tolerance machined components. The Sonic 100 blower head is rated for a 20,000 RPM maximum impeller speed. Sonic uses only the best internal components for the blower head assembly and is confident that the head will perform exceptionally in the application it was designed to perform. As with all moving components, the blower head is subject to wear and eventually will fail. Periodic maintenance and inspections will ensure the longest possible life expectancy for the blower head. The most typical mode of failure will be from the shaft bearings and with periodic inspections; this failure can be predicted to some extent. Sonic can also provide a thermocouple option to monitor the temperature of the bearing housing which is used to predict an imminent bearing failure.

Due to the complexity of the internal assembly, the precision components, and the experience of Sonic assembly and repair technicians; it is not recommended that the unit be serviced or repaired in the field. Any attempt to repair the unit within the warranty period will void the warranty. Sonic does offer a repair program in the event the blower fails outside of the warranty period and the blower head is not severely worn or damaged. Sonic recommends that in the event that a blower failure will cause interrupted production, a replacement blower head be purchased as a spare item.

Follow the below return authorization procedure when requesting a blower head repair:

Sonic Air Systems, Inc. (SAS) recognizes the need to return product in certain circumstances. SAS requests written return authorization to track incoming shipments and to efficiently process any repairs or credit invoices.

Repair Return Authorization Procedure

- Buyer issues a purchase order requesting and authorizing a blower head repair (reference purchase order requirements)
- A repair order number will be communicated by 4:30pm PST
- The blower head must include the blower pulley
- The repair order number must be noted on the outside of the shipping container
- Buyer will ship F.O.B. destination freight prepaid to SAS factory
- Non-compliance to any of the above procedures, damage resulting from improper packaging, or product exposed to a hazardous substance may result in SAS refusing shipment
- Repairs will be shipped within 24 hours of receipt in the USA and within 48 hours of receipt internationally



Documento:
Document:

VENDOR DATA BOOK

Oggetto:
Object:

AIR BLADES SYSTEM FOR DRYER

1.2 Blower data sheet



Product Specification Sheet

SONIC 300
CENTRIFUGAL BLOWER
IEC

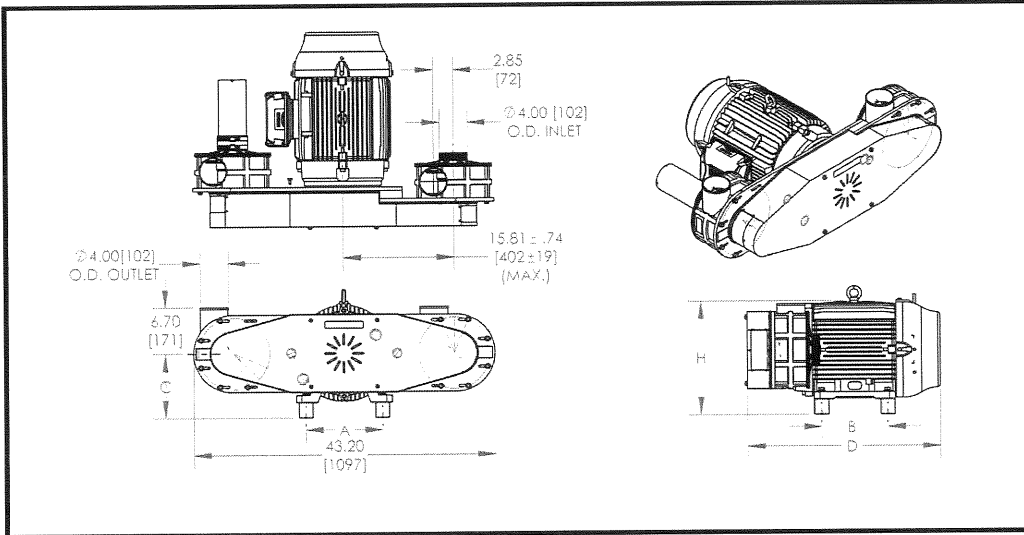
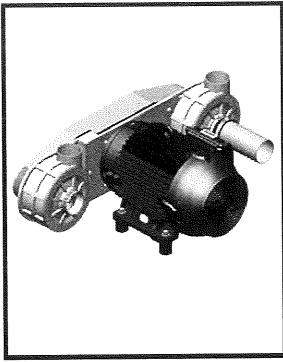

Dimensions in brackets () are in millimeters

Description	Blower – Sonic 300				Blower –Sonic 300 Water Cooled			
	Output Flow Rate	1,200 cfm (567 lps) to 2,400 cfm (1,133 lps)				1,200 cfm (567 lps) to 2,400 cfm (1,133 lps)		
Ambient Temperature	10°F (-12°C) to 105°F (40°C)				10°F (-12°C) to 105°F (40°C)			
Air Temperature Range	< 125°F (52°C)				125°F (52°C) to 400°F (205°C)			
Motors Available	18.5 kW (25 Hp)	22 kW (30 Hp)	30 kW (40 Hp)	37 kW (50 Hp)	18.5 kW (25 Hp)	22 kW (30 Hp)	30 kW (40 Hp)	37 kW (50 Hp)
Depth (D)	27.70in (704mm)	29.15 in (741mm)	30.20 in (768mm)	30.20 in (768mm)	27.70in (704mm)	29.15 in (741mm)	30.20 in (768mm)	30.20 in (768mm)
Height (H)	15.80 in (402mm)	16.00 in (407mm)	18.20 in (463mm)	18.20 in (463mm)	15.80 in (402mm)	16.00 in (407mm)	18.20 in (463mm)	18.20 in (463mm)
Mounting Pattern (A)	11.00 in (280mm)	11.00 in (280mm)	12.50 in (318mm)	12.50 in (318mm)	11.00 in (280mm)	11.00 in (280mm)	12.50 in (318mm)	12.50 in (318mm)
Mounting Pattern (B)	9.50 in (241mm)	11.00 in (280mm)	10.50 in (267mm)	10.50 in (267mm)	9.50 in (241mm)	11.00 in (280mm)	10.50 in (267mm)	10.50 in (267mm)
Drive Center-Line (C)	9.15 in (233mm)	9.15 in (233mm)	10.25 in (261mm)	10.25 in (261mm)	9.15 in (233mm)	9.15 in (233mm)	10.25 in (261mm)	10.25 in (261mm)
Approximate Weight	508 lbs (230 kg)	508 lbs (230 kg)	508 lbs (230 kg)	508 lbs (230 kg)	508 lbs (230 kg)	508 lbs (230 kg)	508 lbs (230 kg)	508 lbs (230 kg)
Replacement 16 Groove Belt P/N								
Pulley 1.50 to 2.20 Diameter	13451							

Blower Motor_300 IEC
Rev: A
Date: 07/2014



Documento:
Document:

VENDOR DATA BOOK

Oggetto:
Object:

AIR BLADES SYSTEM FOR DRYER

1.3 Motor technical specification



No.: 15845 50hz

Date: 2/2/2011

DATA SHEET

Three-phase induction motor - Squirrel cage rotor

Customer : 05036ET3E326TSC-W22
Product line : W22 NEMA Premium

Frame : 326TS
Output : 50 HP
Frequency : 50 Hz
Poles : 2
Full load speed : 2935
Slip : 2.17 %
Voltage : 380 V
Rated current : 69.4 A
Locked rotor current : 333 A
Locked rotor current (I_L/I_n) : 4.8
No-load current : 14.8 A
Full load torque : 88.3 lb.ft
Locked rotor torque : 170 %
Breakdown torque : 180 %
Design : B
Insulation class : F
Temperature rise : 105 K
Locked rotor time : 18 s (hot)
Service factor : 1.00
Duty cycle : S1
Ambient temperature : -20°C - +40°C
Altitude : 1000 m
Degree of Protection : IP55
Approximate weight : 584 lb
Moment of inertia : 5.7469 sq.ft.lb
Noise level : 69 dB(A)

	D.E.	N.D.E.	Load	Power factor	Efficiency (%)
Bearings	6312 C3	6212 C3	100%	0.89	91.0
Regreasing interval	12000 h	15000 h	75%	0.88	92.4
Grease amount	21 g	13 g	50%	0.86	93.0

Notes:

Performed by:

Checked:



Sonic Air Systems

No.: 50 hp NEMA

Date: 9/20/2010

Customer : Mittal

TECHNICAL PROPOSAL

Three-phase induction motor - Squirrel cage rotor

Product line : Three-Phase : W21 TEFC (IP55) - Ball Bearings - High Efficiency

Catalog Number :

List Price :

Notes:

Three-Phase : W21 TEFC (IP55) - Ball Bearings - High Efficiency

Performed by:

Checked:



Sonic Air Systems

No.: 50 hp NEMA

Date: 9/20/2010

DATA SHEET Three-phase induction motor - Squirrel cage rotor

Customer : Mittal
 Product line : Three-Phase : W21 TEFC (IP55) - Ball Bearings - High Efficiency

Frame : 326TS
 Output : 50 HP
 Frequency : 50 Hz
 Poles : 2
 Full load speed : 2930
 Slip : 2.33 %
 Voltage : 380 V
 Rated current : 69.2 A
 Locked rotor current : 339 A
 Locked rotor current (I_L/I_n) : 4.9
 No-load current : 12.5 A
 Full load torque : 88.4 lb.ft
 Locked rotor torque : 180 %
 Breakdown torque : 180 %
 Design : B
 Insulation class : F
 Temperature rise : 105 K
 Locked rotor time : 25 s (hot)
 Service factor : 1.00
 Duty cycle : S1
 Ambient temperature : -20°C - +40°C
 Altitude : 1000 m
 Degree of Protection : IP55
 Approximate weight : 570 lb
 Moment of inertia : 5.3212 sq.ft.lb
 Noise level : 74 dB(A)

	D.E.	N.D.E.	Load	Power factor	Efficiency (%)
Bearings	6312 C3	6212 C3	100%	0.90	90.2
Regreasing interval	9829 h	12143 h	75%	0.89	91.0
Grease amount	21 g	13 g	50%	0.86	91.7

Notes:

Performed by:

Checked:



Sonic Air Systems

No.: 50 hp NEMA

Date: 9/20/2010

PERFORMANCE CURVES RELATED TO RATED OUTPUT

Three-phase induction motor - Squirrel cage rotor

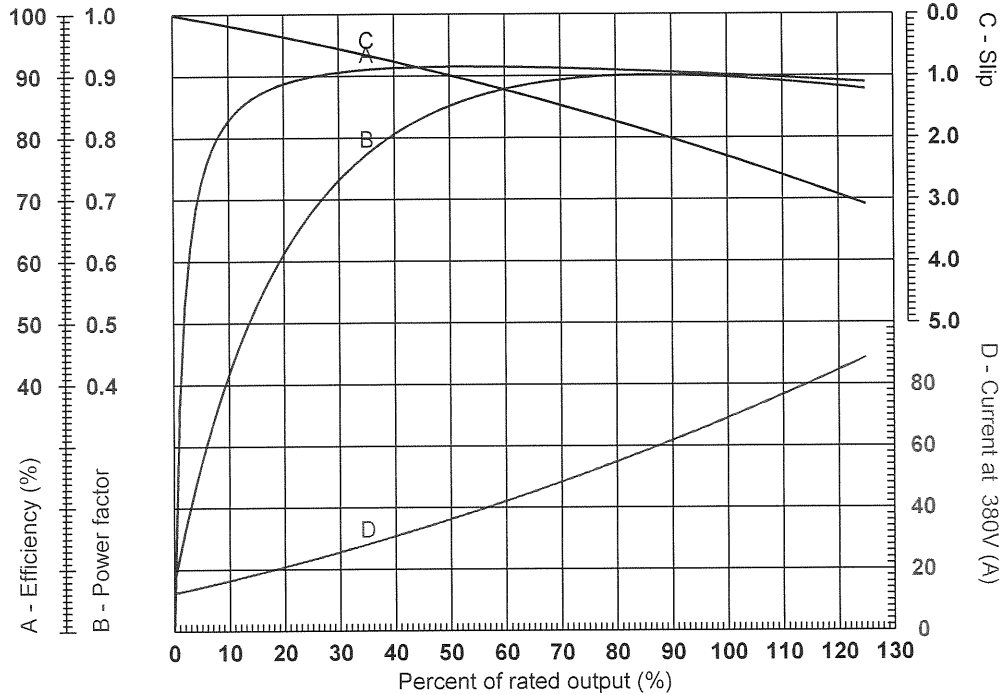

Customer : Mittal
Product line : Three-Phase : W21 TEFC (IP55) - Ball Bearings - High Efficiency

Output	: 50 HP	Locked rotor current (I _L /I _n)	: 4.9
Frame	: 326TS	Duty cycle	: S1
Full load speed	: 2930	Service factor	: 1.00
Frequency	: 50 Hz	Design	: B
Voltage	: 380 V	Locked rotor torque	: 180 %
Insulation class	: F	Breakdown torque	: 180 %
Rated current	: 69.2 A		

Notes:

Performed by:

Checked:



Sonic Air Systems

No.: 50 hp NEMA

Date: 9/20/2010

CHARACTERISTIC CURVES RELATED TO SPEED

Three-phase induction motor - Squirrel cage rotor

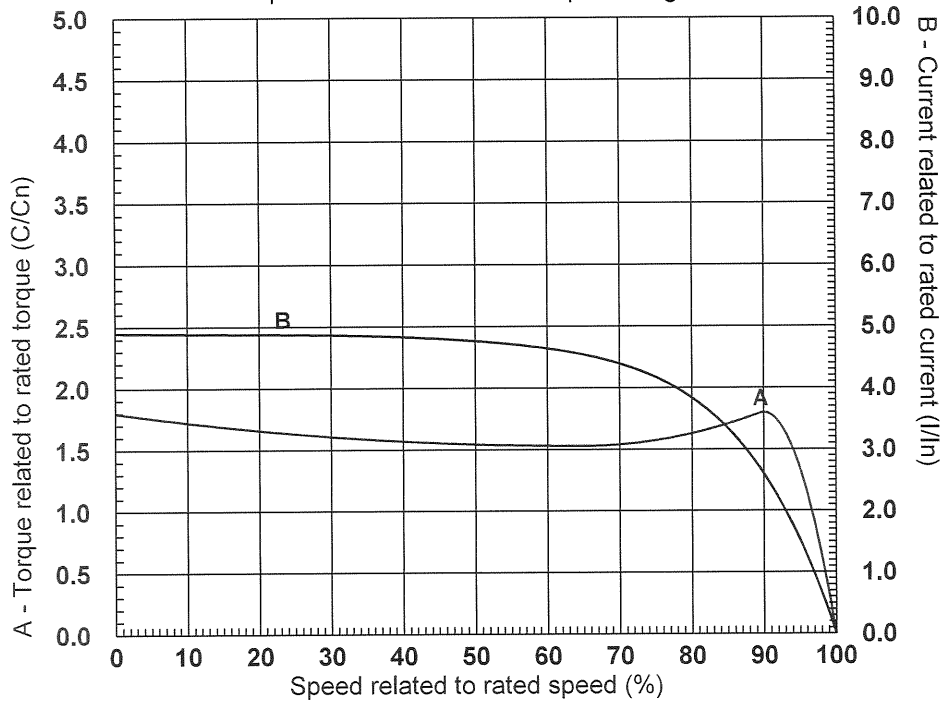

Customer : Mittal
Product line : Three-Phase : W21 TEFC (IP55) - Ball Bearings - High Efficiency

Output	: 50 HP	Locked rotor current (I _l /I _n)	: 4.9
Frame	: 326TS	Duty cycle	: S1
Full load speed	: 2930	Service factor	: 1.00
Frequency	: 50 Hz	Design	: B
Voltage	: 380 V	Locked rotor torque	: 180 %
Insulation class	: F	Breakdown torque	: 180 %
Rated current	: 69.2 A		

Notes:

Performed by:

Checked:

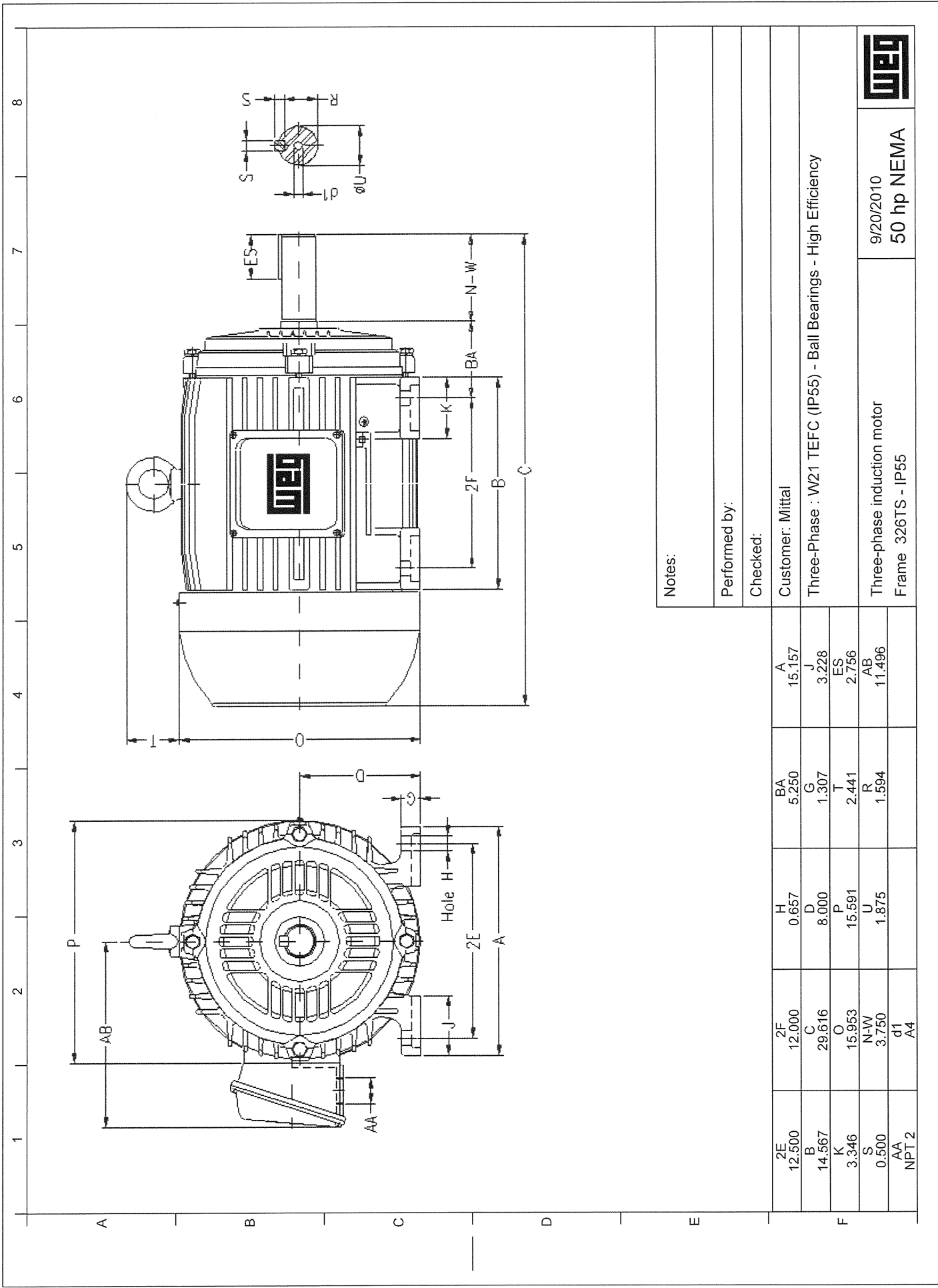

Notes:	
Performed by:	
Checked:	
Customer:	Mittal
Three-Phase : W21 TEFC (IP55) - Ball Bearings - High Efficiency	
Three-phase induction motor Frame 326TS - IP55	
	
9/20/2010 50 hp NEMA	

2E	12.500	2F	12.000	H	0.657	BA	5.250	A	15.157
B	14.567	C	29.616	D	8.000	G	1.307	J	3.228
K	3.346	O	15.953	P	15.591	T	2.441	ES	2.756
S	0.500	N+W	3.750	U	1.875	R	1.594	AB	11.496
AA	NPT 2	d1	A4						



Documento:
Document:
Oggetto:
Object:

VENDOR DATA BOOK

AIR BLADES SYSTEM FOR DRYER

1.4 Enclosure data sheet



Component Specification Sheet

- Blower Enclosures -

Interface Dimensions

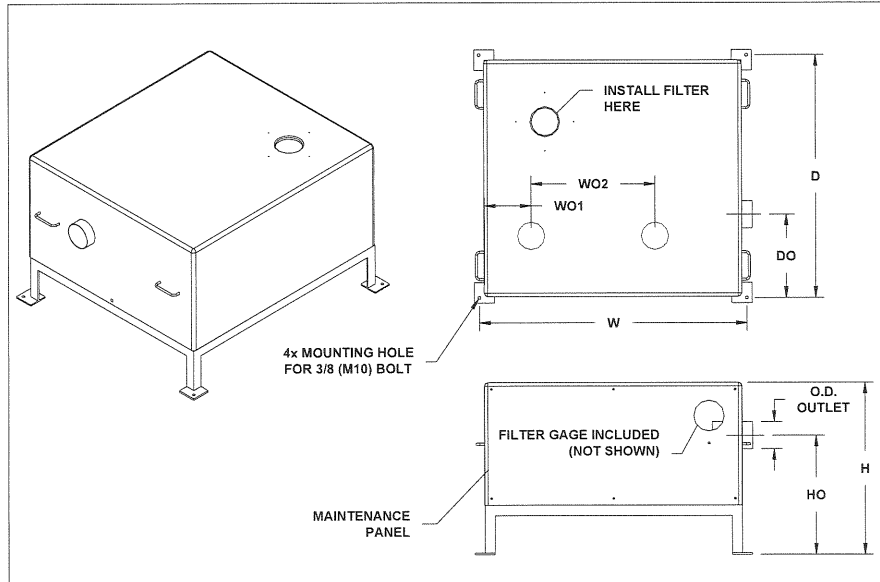

Component Specifications

Description	Enclosure – Sonic 70		Enclosure – Sonic 100		Enclosure – Sonic 300	
	Indoor	Washdown / Outdoor	Indoor	Washdown / Outdoor	Indoor	Washdown / Outdoor
Sonic P/N	11099	12878	11100	12716	12550	12880
Noise Level	< 85 db		< 85 db		< 85 db	
O.D. Outlet	3.0 in (76 mm)		4.0 in (102 mm)		4.0 in (102 mm)	
Width (W)	33.5 in (851 mm)		39.5 in (1004 mm)		49.5 in (1,258 mm)	
Depth (D)	29.5 in (750 mm)		35.5 in (902 mm)		37.5 in (953 mm)	
Height (H)	22.3 in (566 mm)		25.3 in (642 mm)		37.0 in (940 mm)	
Outlet Width (WO)	N/A		N/A		WO1 = 11.4 in WO2 = 31 in	
Outlet Depth (DO)	10.5 in (267 mm)		12.25 in (312 mm)		10.5 in (267 mm)	
Outlet Height (HO)	16.75 in (426 mm)		17.50 in (445 mm)		11.63 in (296 mm)	
Material	Polypropylene Cover ⁽¹⁾ C.S. Base ⁽²⁾		Polypropylene Cover ⁽¹⁾ C.S. Base ⁽²⁾		Polypropylene Cover ⁽¹⁾ C.S. Base ⁽²⁾	
Finish	Powder Coat Base		Powder Coat Base		Powder Coat Base	
Approximate Weight	120 lbs (54.5 kg)	135 lbs (61.4 kg)	165 lbs (75.0 kg)	180 lbs (81.8 kg)	295 lbs (134.1 kg)	325 lbs (147.7 kg)

⁽¹⁾304 S.S. Cover (Electropolish Finish) is available upon request

⁽²⁾304 S.S. Base (Electropolish Finish) is available upon request



Documento:
Document:

VENDOR DATA BOOK

Oggetto:
Object:

AIR BLADES SYSTEM FOR DRYER

1.5 Air knife data sheet



Component Specification Sheet

- High Velocity 6" Air Knife -

Interface Dimensions

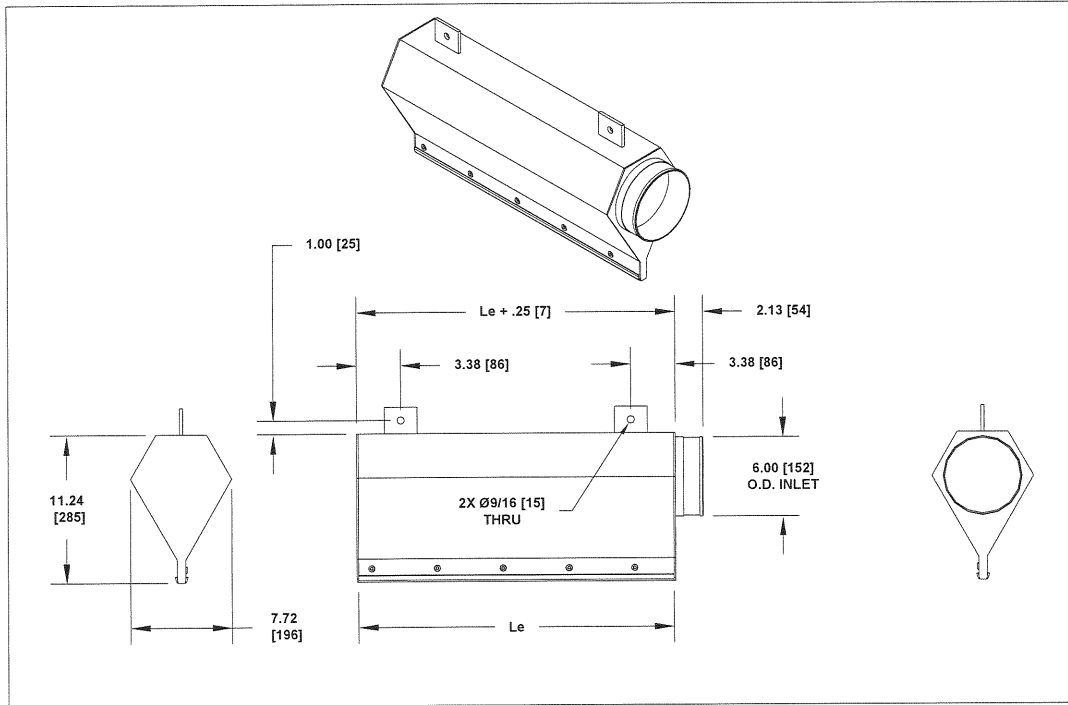

Component Specifications

Description	Air Knife-6" X %% "LG Steel ⁽¹⁾	Air Knife-6" X %% LG SS ⁽¹⁾
Sonic Part Number	14505-%%	Custom
Maximum Custom Slot Length (Le)	72.0 inches (1,830 mm)	
Air Knife Inlet Orientations	<u>View Orientations</u>	
Material	Carbon Steel	300 Series Stainless Steel
Finish	Powder Painted	Electropolish
Approximate Weight	12.5 lbs/ft (18.9 kg/m)	

⁽¹⁾ %% denotes effective slot length



Documento:
Document:

VENDOR DATA BOOK

Oggetto:
Object:

AIR BLADES SYSTEM FOR DRYER

1.5.1 Air Knife Gap and Weld instructions

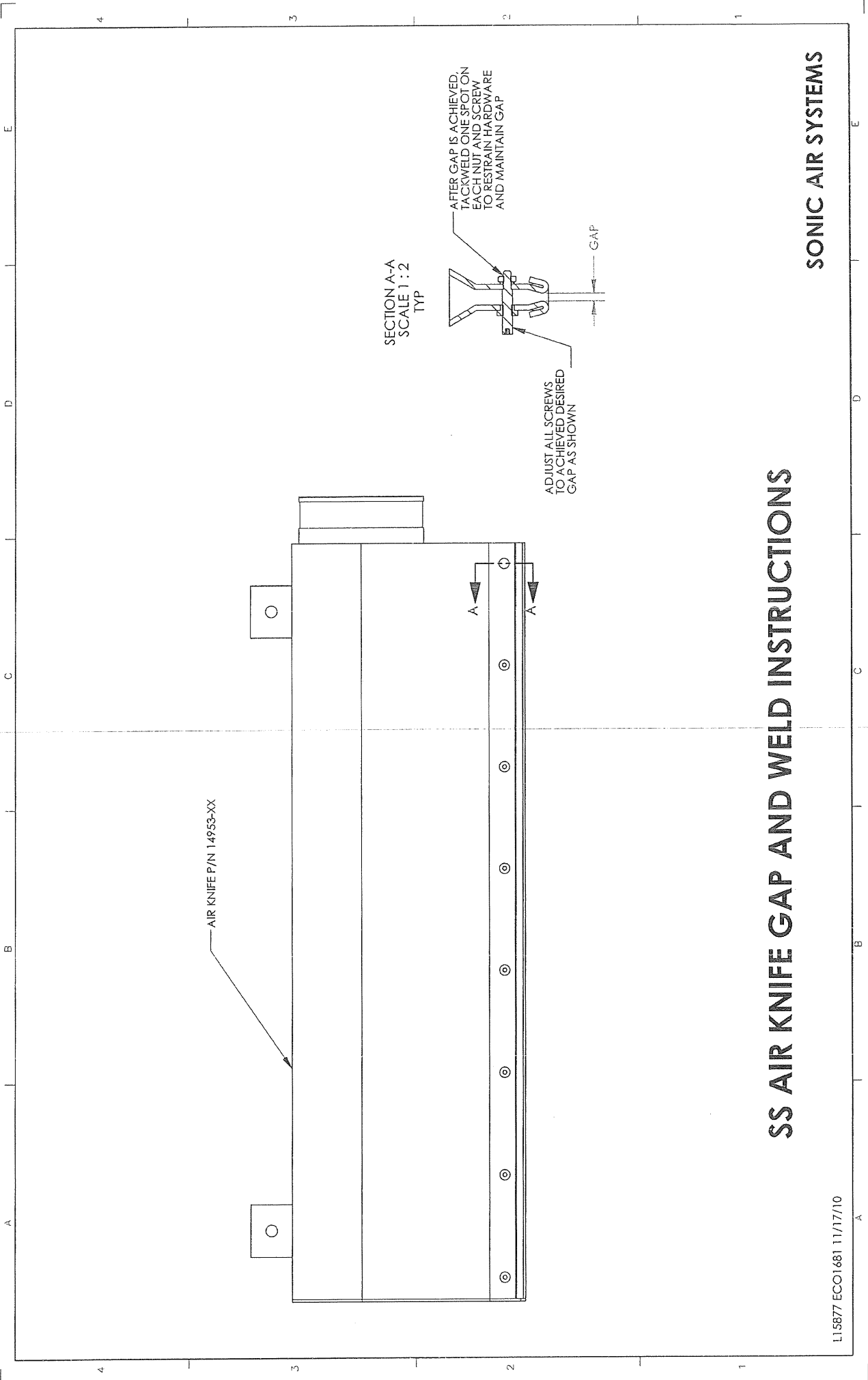

AIR KNIFE P/N 14953-XX

SECTION A-A
SCALE 1:2
TYP

ADJUST ALL SCREWS
TO ACHIEVED DESIRED
GAP AS SHOWN

AFTER GAP IS ACHIEVED,
TACKWELD ONE SPOT ON
EACH NUT AND SCREW
TO RESTRAIN HARDWARE
AND MAINTAIN GAP

GAP

SS AIR KNIFE GAP AND WELD INSTRUCTIONS

SONIC AIR SYSTEMS



Documento:
Document:

VENDOR DATA BOOK

Oggetto:
Object:

AIR BLADES SYSTEM FOR DRYER

2 Annexes



Documento:

Document:

Oggetto:

Object:

VENDOR DATA BOOK

AIR BLADES SYSTEM FOR DRYER

2.1 Material Certificates



New Zealand Steel Limited
 A BlueScope Company
 531 Mission Bush Road, Glendora, South Auckland
 Postal Private Bag 20121, Auckland 1142, New Zealand
 Telephone: (09) 375 8111 Auckland
 Fax: (09) 375 8958



ACCREDITED APPROVAL

TEST CERTIFICATE

CUSTOMER	CUSTOMER O/N	HEAT No	PACK NUMBER	HEAT No	PACK NUMBER
	109258	936579	1091763500	936579	1091763500
MILL O/N	1137964				
SPECIFICATION	ASTM A36(2012)				
PRODUCT	HOT ROLLED COIL				
DIMENSIONS	0.245" x 48" x C (ml)				
USER REF	CC1275-1				
CERTIFICATE No	TC348196				
DATE	30 December 2015				
TEST METHOD	ASTM A370				

CHEMICAL COMPOSITION PERCENT (TEST METHOD) - ASTM A36 & HS (G15)		MECHANICAL TEST (TEST METHOD)		CARBON EQUIVALENT VALUE (CE)																
C	Si	Mn	P	S	Fe	YIELD	TENSILE	ELONG	HARDNESS	TEST DIR										
x1000						(B) psi	(A) ksi	%	HR											
17	TR	57	15	15	13	15	23	1	8	1	59	TR	50	27	NA	46100	66000	24	NA	

CHEM COMP %	Si (TR) < 0.01%	Mn (TR) < 0.01%	P (TR) < 0.001%	S (TR) < 0.001%	Fe (TR) < 0.001%	TEST DIR	YIELD	GAUGE LENGTH (G.L.)	IMPACT TEST	CARBON EQUIVALENT VALUE (CE)
							(A)=0.2% (B)=LOWER	(A)=200mm (B)=50mm	(A)=10mm x 10mm (B)=7.5mm x 10mm	(A)=C-Mn06 (B)=C-Mn06+(Cr+V+Mo)/5+(Cu+Ni)/15

* Steel produced through the basic oxygen steelmaking process by New Zealand Steel
 * Heat analyzed from ladle
 * Results relate to test on a representative sample of the items covered in this test certificate
 * This certificate may not be reproduced except in full
 * New Zealand Steel, Chemical Laboratory IANZ Accreditation Number 101, KIP, Mr David Shere

WE HEREBY CERTIFY THAT THE MATERIAL DESCRIBED HEREIN HAS BEEN TESTED AND INSPECTED WITH SATISFACTORY RESULTS IN ACCORDANCE WITH THE REQUIREMENTS OF THE ABOVE SPECIFICATION

APPROVED: *Andrew Mackenzie*
 SENIOR METALLURGIST

Page 1 of 1



Documento:
Document:
Oggetto:
Object:

VENDOR DATA BOOK

AIR BLADES SYSTEM FOR DRYER

2.2 P&ID

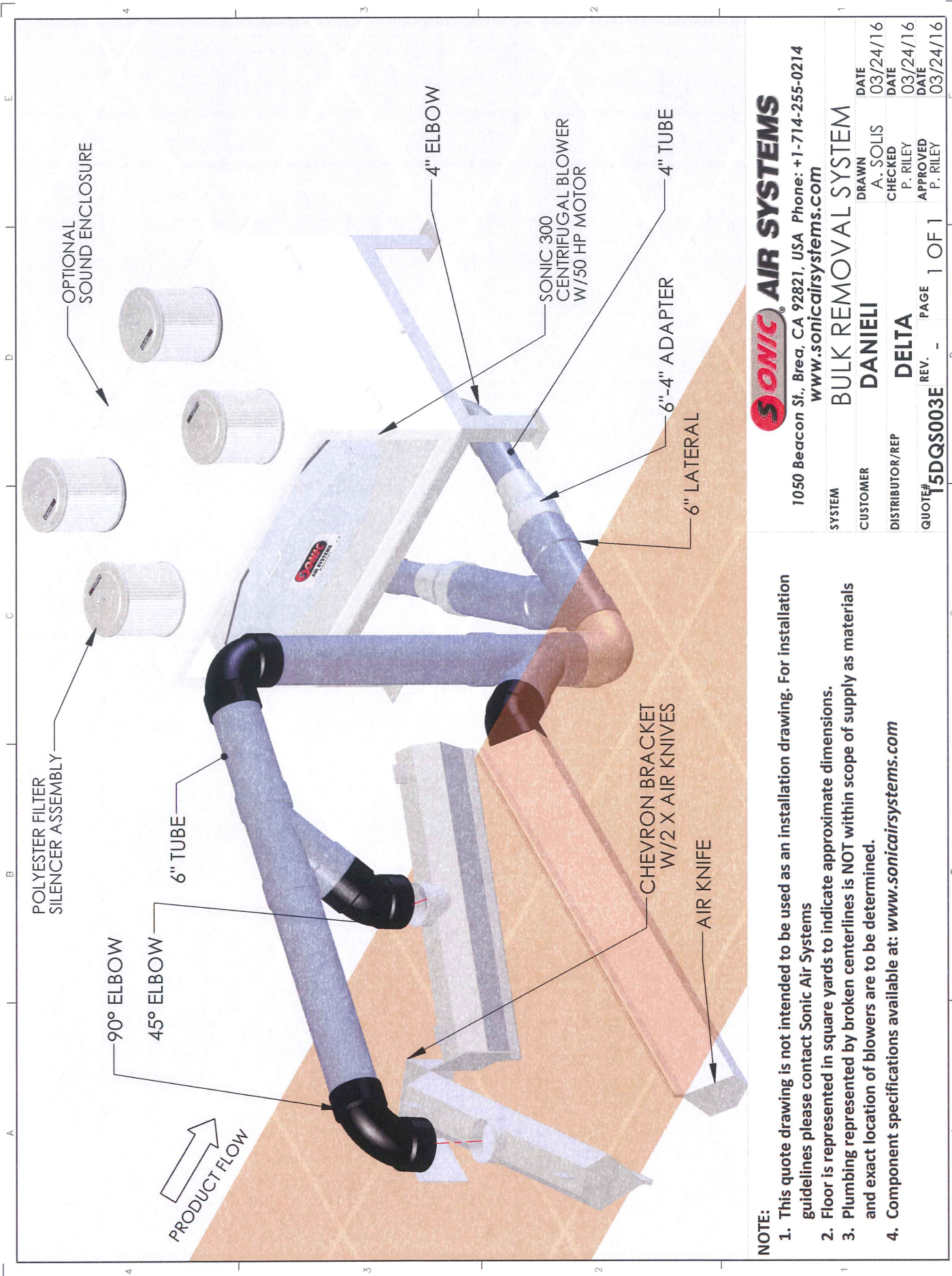

NOTE:

1. This quote drawing is not intended to be used as an installation drawing. For installation guidelines please contact Sonic Air Systems
2. Floor is represented in square yards to indicate approximate dimensions.
3. Plumbing represented by broken centerlines is NOT within scope of supply as materials and exact location of blowers are to be determined.
4. Component specifications available at: www.sonicairstystems.com



1050 Beacon St., Brea, CA 92821, USA Phone: +1-714-255-0214
www.sonicairstystems.com

SYSTEM		BULK REMOVAL SYSTEM	
CUSTOMER	DANIELI		
DRAWN	A. SOLIS	DATE	03/24/16
DISTRIBUTOR/REP	DELTA	CHECKED	DATE
QUOTE#	REV.	PAGE	DATE
15DQS003E	-	1 OF 1	03/24/16